

Trouble Shooting	Possible cause	Correction
<b>SPRINKLER DOES NOT START UP</b> 1, 2, 4, 5, 9	<b>1</b> Nozzle damaged	Replace nozzle
<b>SPRINKLER STOPS</b> 1, 2, 3, 4, 5, 6, 9, 10	<b>2</b> Deflector damaged	Replace kit deflector
<b>SPRINKLER ROTATES SLOWLY</b> 1, 2, 3, 4, 5, 8, 9, 10	<b>3</b> Brake System assembly rotation hard/seized	Replace kit brake/seals
<b>SPRINKLER DOES NOT INVERT</b> 1, 2, 4, 5, 6, 7, 9	<b>4</b> Poor system pressure	Check pressure, elevation change, booster pump
<b>SPRINKLER THROW SHORTENED</b> 1, 4, 9	<b>5</b> Drive arm hindered in its movement	Disassemble and check for wear parts and debris
	<b>6</b> Trip spring damaged	Replace kit trip springs
	<b>7</b> Trip stop ring out of its grooves	Position trip stop ring correctly
	<b>8</b> Speed selector in wrong position	Adjust speed selector correctly
	<b>9</b> Sprinkler partially/totally plugged	Check inside of gun to be free of debris
	<b>10</b> Sloping terrain	Install counterweight

Fehlersuche	Mögliche Ursachen	Abhilfe
<b>REGNER STARTET NICHT</b> 1, 2, 4, 5, 9	<b>1</b> Düse beschädigt	Düse erneuern
<b>REGNER BLEIBT STEHEN</b> 1, 2, 3, 4, 5, 6, 9, 10	<b>2</b> Deflektor beschädigt	Kit Deflektor erneuern
<b>REGNER DREHT LANGSAM</b> 1, 2, 3, 4, 5, 8, 9, 10	<b>3</b> Bremssystem dreht nicht oder schwer	Kit Bremse/Dichtungen erneuern
<b>REGNER WENDET NICHT</b> 1, 2, 4, 5, 6, 7, 9	<b>4</b> Betriebsdruck zu nieder	Druck, Höhenunterschied, Druckerhöhungspumpe kontrollieren
<b>WURFWEITE VERKÜRZT</b> 1, 4, 9	<b>5</b> Schwingarm in seiner Bewegung nicht frei	Abbauen und auf Verschleiss und Schmutz kontrollieren
	<b>6</b> Sektorfeder beschädigt	Kit Sektorfeder erneuern
	<b>7</b> Sektoring nicht in seiner Nut positioniert	Sektoring in seine Nut geben
	<b>8</b> Geschwindigkeitsregulierung falsch	Geschwindigkeitsregulierung richtig einstellen
	<b>9</b> Regner teilweise oder zur Gänze verstopft	Regner innen auf freien Durchfluss kontrollieren
	<b>10</b> Hanglage	Gegengewicht montieren

Ricerca Guasti	Probabile causa	Rimedio
<b>L'IRRIGATORE NON PARTE</b> 1, 2, 4, 5, 9	<b>1</b> Ugello danneggiato	Sostituire l'ugello
<b>L'IRRIGATORE SI FERMA</b> 1, 2, 3, 4, 5, 6, 9, 10	<b>2</b> Deflettore danneggiato	Sostituire il kit deflettore
<b>L'IRRIGATORE GIRA LENTO</b> 1, 2, 3, 4, 5, 8, 9, 10	<b>3</b> Rotazione lenta/bloccata del sistema freno	Sostituire il kit freno e/o guarnizioni
<b>L'IRRIGATORE NON INVERTE</b> 1, 2, 4, 5, 6, 7, 9	<b>4</b> Pressione d'esercizio insufficiente	Controllare pressione, dislivello e pompa di rilancio
<b>LA GITTATA È RIDOTTA</b> 1, 4, 9	<b>5</b> Braccio oscillante legato nel suo movimento	Smontare e controllare per usura e/o corpi estranei
	<b>6</b> Molla scatto settore danneggiata	Sostituire il kit molla scatto settore
	<b>7</b> Anello settore posizionato fuori dalla sua sede	Posizionare correttamente l'anello settore
	<b>8</b> Selettore velocità regolato in posizione non corretta	Regolare correttamente la velocità
	<b>9</b> Irrigatore parzialmente/totamente otturato	Liberare l'interno dell'irrigatore da possibili detriti
	<b>10</b> Terreno con pendenza	Installare un contrappeso

Aide au Dépannage	Cause possible	Remède
<b>L'ARROSEUR NE DÉMARRE PAR</b> 1, 2, 4, 5, 9	<b>1</b> Buse endommagée	Remplacer la buse
<b>L'ARROSEUR S'ARRÊTE</b> 1, 2, 3, 4, 5, 6, 9, 10	<b>2</b> Déflecteur endommagé	Remplacer le kit déflecteur
<b>L'ARROSEUR TOURNE LENTEMENT</b> 1, 2, 3, 4, 5, 8, 9, 10	<b>3</b> La rotation du système de frein est bloquée/dure	Remplacer le kit frein/joints
<b>L'ARROSEUR NE S'INVERSE PAS</b> 1, 2, 4, 5, 6, 7, 9	<b>4</b> Pression système insuffisante	Vérifier la pression du système, le dénivelé, le surpresseur
<b>LA PORTÉE EST RÉDUITE</b> 1, 4, 9	<b>5</b> Le bras oscillant est entravé dans son mouvement	Démonter et rechercher pièces usées et/ou débris
	<b>6</b> Ressort inversion endommagé	Remplacer le kit ressort inversion
	<b>7</b> Anneau secteur hors de son siège	Positionner correctement l'anneau secteur
	<b>8</b> Régulateur vitesse mal positionné	Régler correctement la vitesse
	<b>9</b> Arroseur partiellement/complètement bouché	Vérifier que l'intérieur du canon ne contient aucun débris
	<b>10</b> Terrain en pente	Installer un contrepoids

Detección de Fallos	Posibles causas	Corrección
<b>EL ASPERSOR NO ARRANCA</b> 1, 2, 4, 5, 9	<b>1</b> Boquilla dañada	Sustituir la boquilla
<b>EL ASPERSOR SE DETIENE</b> 1, 2, 3, 4, 5, 6, 9, 10	<b>2</b> Deflector dañado	Sustituir el kit deflector
<b>EL ASPERSOR ROTA LENTAMENTE</b> 1, 2, 3, 4, 5, 8, 9, 10	<b>3</b> Rotación del sistema del freno lenta/bloqueado	Sustituir el kit de freno/guarnición
<b>EL ASPERSOR NO INVIERTE</b> 1, 2, 4, 5, 6, 7, 9	<b>4</b> Presión de servicio insuficiente	Controlar presión, diferencia de nivel, rebombeo
<b>ALCANCE REDUCIDO</b> 1, 4, 9	<b>5</b> Brazo oscilante obstaculizado en su movimiento	Desmontar y controlar si hay desgaste o suciedad
	<b>6</b> Muelle sector dañado	Sustituir el kit muelle sector
	<b>7</b> Anillo sector fuera de su ranura	Posicionar el muelle sector en su ranura
	<b>8</b> Selector de velocidad en posición incorrecta	Regular correctamente la velocidad
	<b>9</b> Aspersor parcialmente/totamente obstruido	Comprobar que el interior del aspersor esté libre de residuos
	<b>10</b> Terreno en pendiente	Instalar contrapeso

Identificação de Defeitos	Causa possível	Solução
<b>O ASPERSOR NÃO ARRANCA</b> 1, 2, 4, 5, 9	<b>1</b> Bocal danificado	Substituir o bocal
<b>O ASPERSOR PÁRA</b> 1, 2, 3, 4, 5, 6, 9, 10	<b>2</b> Defletor danificado	Substituir o kit defletor
<b>O ASPERSOR GIRA LENTAMENTE</b> 1, 2, 3, 4, 5, 8, 9, 10	<b>3</b> Rotação sistema do freio endurecido/agarrado	Substituir kit de freio/guarnição
<b>O ASPERSOR NÃO INVERTE</b> 1, 2, 4, 5, 6, 7, 9	<b>4</b> Pressão do sistema insuficiente	Verificar o pressão do sistema, elevação e bomba de reforço
<b>O ASPERSOR COM JATO REDUZIDO</b> 1, 4, 9	<b>5</b> Braço oscilante travado em seu movimento	Desmontar e verificar se há peças desgastadas e/ou detritos
	<b>6</b> Mola de setor danificado	Substituir kit mola de setor
	<b>7</b> Anel de setor fora de seu alojamento	Posicionar corretamente o anel nos sulcos
	<b>8</b> Seletor de velocidade na posição errada	Ajuste o seletor de velocidade corretamente
	<b>9</b> Aspersor parcialmente/totamente entupido	Verificar que ao interno do canhão esteja livre de detritos
	<b>10</b> Terrenos inclinados	Instale contrapeso

Never service the gun while in operation.

Niemals während des Betriebes Einstellungen/Wartungen am Regner durchführen.

Non eseguire operazioni sull'apparecchio in funzione.

Ne pas faire d'interventions sur le canon en marche.

Nunca efectuar trabajos sobre el cañon en marcha.

Nunca execute operações com o canhão em marcha.

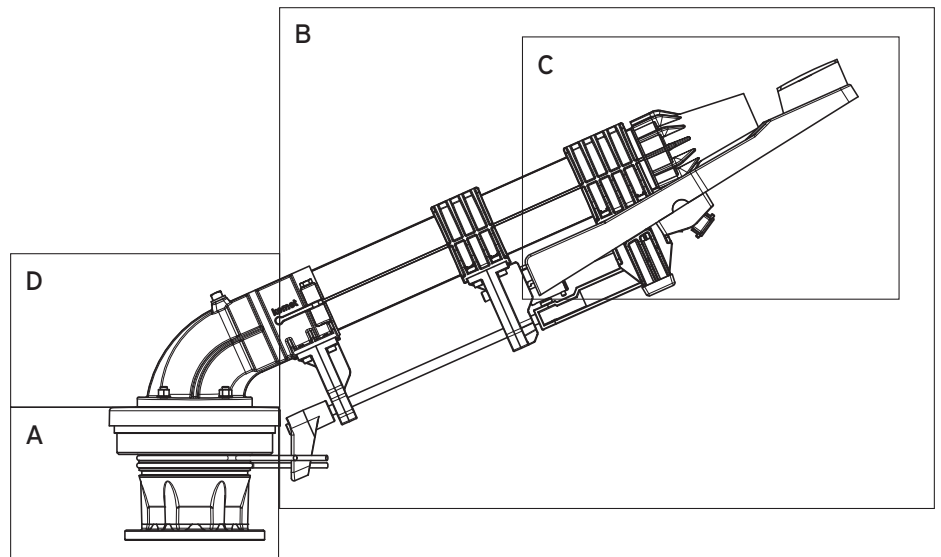

#### INSTRUCTIONS:

1. All moving parts have to be free.
2. When greasing, use a soft, water resistant quality grease brand.
3. The brake surfaces should never come in contact with grease.
4. If parts have to be replaced, use the Assemblies or Kits as shown in the spare parts list, this assures a simple and complete service. For replacement follow the sequence as shown hereafter.
5. For trouble shooting it is advantageous to have the spare parts list on hand.

#### ANLEITUNG:

1. Alle Bewegungen müssen frei und leichtgängig sein.
2. Zum Fetten, ein weiches, wasserfestes Fett verwenden.
3. Die Bremsscheiben dürfen niemals mit Fett in Berührung kommen.
4. Beim Austauschen von Teilen sich der Teile-Sätze wie aus der Ersatzteil-Liste hervorgeht (fett gedruckt) bedienen, dadurch ist eine einfache und umfassende Erneuerung gewährleistet. Für den Zusammenbau, die abgebildeten Sequenzen zur Demontage in umgekehrter Reihenfolge ausführen.
5. Bei der Fehlersuche ist es vorteilhaft, die dem Regner beigelegte Ersatzteil-Liste zur Hand zu haben.

#### ISTRUZIONI:

1. Tutti i movimenti devono essere liberi.
2. Per ingrassare usare un grasso di marca, morbido e resistente all'acqua.
3. Le pastiglie freno non devono venire assolutamente a contatto con grasso.
4. Nella sostituzione di particolari, servirsi dei Kit ricambio preconfezionati come indicati nella lista ricambi (neretto), questo assicura un semplice e completo ripristino. Per il montaggio seguire a ritroso le sequenze di smontaggio illustrate.
5. Per la ricerca guasti è utile avere a disposizione la lista ricambi in dotazione all'apparecchio.

#### INSTRUCTIONS:

1. Toutes les parties articulées doivent se mouvoir librement.
2. Pour graisser, utiliser une bonne graisse molle, résistante à l'eau.
3. Les pastilles frein ne doivent jamais entrer en contact avec la graisse.
4. S'il faut remplacer des pièces, utiliser les kits de rechange, indiqués en gras sur la liste des pièces de rechange, ceci garantit une manutention complète et simple. Pour le montage, suivre à rebours les séquences de démontage illustrées.
5. Pour la recherche des pannes, nous conseillons d'avoir à portée de la main la liste des pièces de rechange fournie avec l'arroseur.

#### INSTRUCCIONES:

1. Todos los movimientos deben ser libres.
2. Para un correcto mantenimiento, usar grasa de calidad de poca densidad (fluida).
3. Las pastillas de freno no deben estar nunca en contacto con grasa.
4. Si debe cambiarse alguna pieza, utilizar los kits de recambios confeccionados que figuran en el catálogo piezas, lo cual garantiza una sencilla y completa reparación. Para el montaje, ver esquemas adjuntos.
5. Para la busca de los desperfectos, aconsejase de tener al alcance de la mano la lista de recambios facilitada con el aspersor.

#### INSTRUÇÕES:

1. Todos os movimentos devem estar livres.
2. Para lubrificação, usar somente graxa de baixa densidade (fluida) e resistente à água.
3. As pastilhas do freio jamais deverão entrar em contacto com a graxa.
4. Se houver necessidade de reposição de peças, utilizar os conjuntos apresentados no catálogo de peças, esse procedimento garante uma manutenção simples e completa. Seguir os procedimentos de montagem e desmontagem apresentados a seguir.
5. Para a identificação de defeitos, é recomendável manter-se a lista de peças de reposição à mão.



Service & Troubleshooting

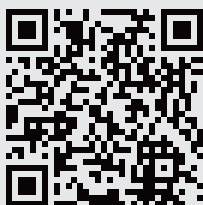

Tools



Werkzeuge

Utensili

Outils

Herramientas

Ferramentas

6 mm  
  
 5 mm  
  
 Hex wrench / Sechskantschlüssel  
 Chiave per brugola / Clé allen  
 Llave hexagonal / Chave allen

13 mm  
  
 Open end wrench / Gabelschlüssel  
 Chiave a forchetta / Clé plate  
 Llave de boca / Chave inglesa

8 mm  
  
 Nut driver / Steckschlüssel  
 Chiave per bussola / Clé à pipe  
 Llave de enchufe / Chave soquete

  
 Flat screwdriver, small  
 Kleiner Schraubenzieher, flach  
 Cacciavite piccolo, piatto  
 Petit tournevis plat  
 Destornillador plano, pequeño  
 Chave de fenda pequena



Nozzle wrench  
 Düsenschlüssel  
 Chiave bocaglio  
 Clé pour buse  
 Llave-boquilla  
 Chave para bocal

A

Bearing  
 Hauptlager  
 Corpo Cuscinetto  
 Corps Roulement  
 Cuerpo Cojinete  
 Conjunto Rolamento

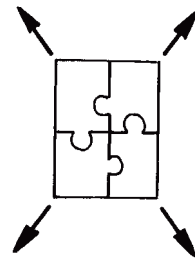

01

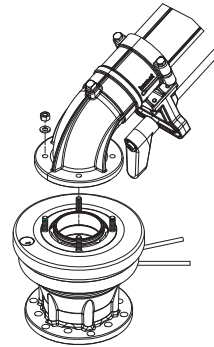

02

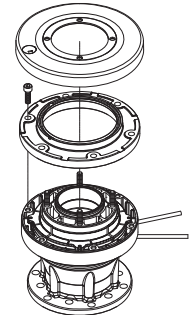

03

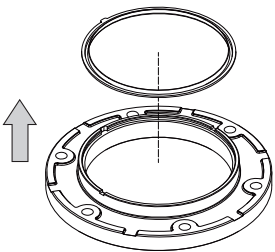

04

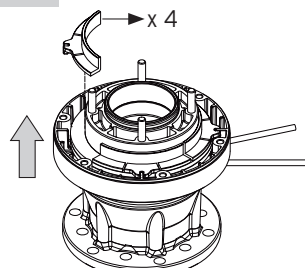

05

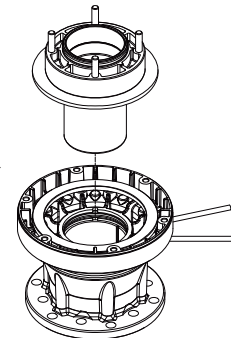

06

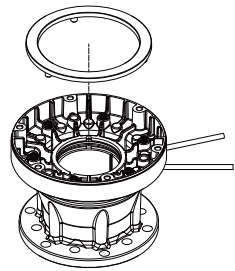

07

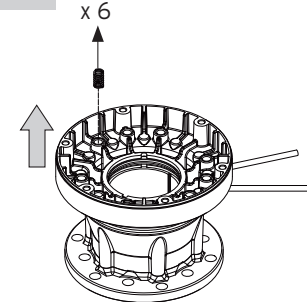

08

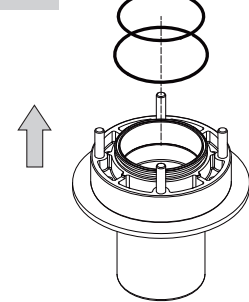

09

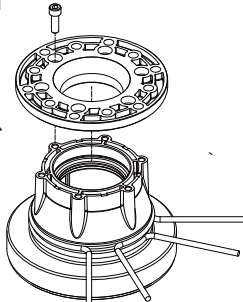

10

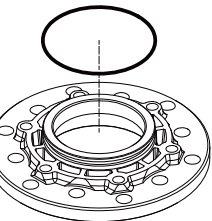

11

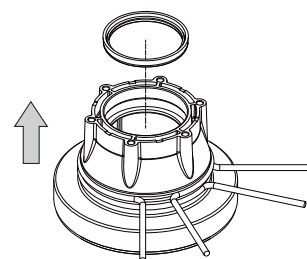

12

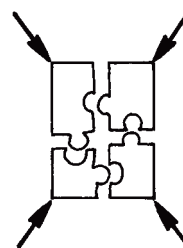
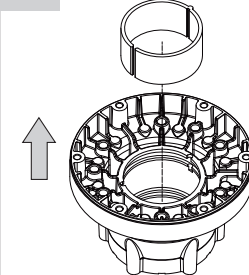

13

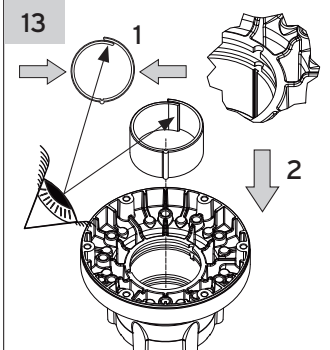

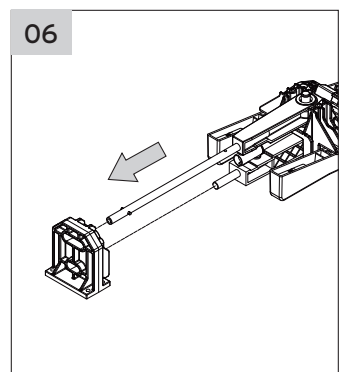
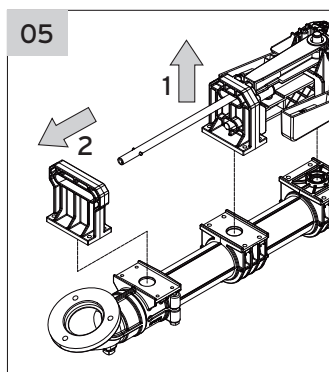
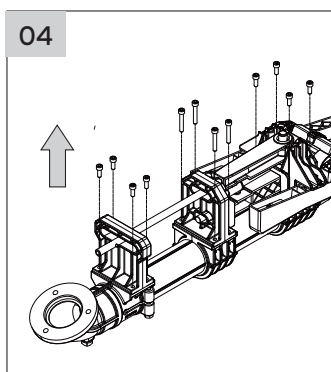
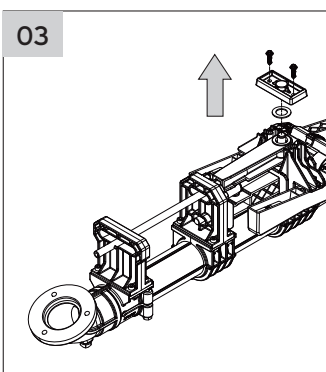
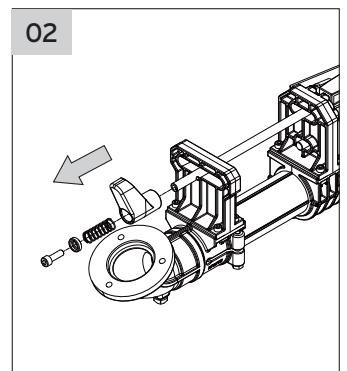
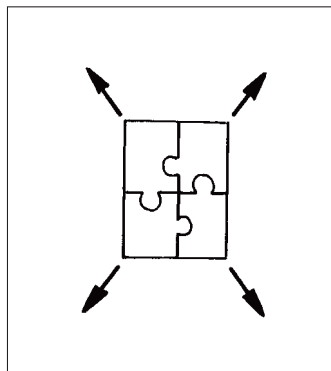
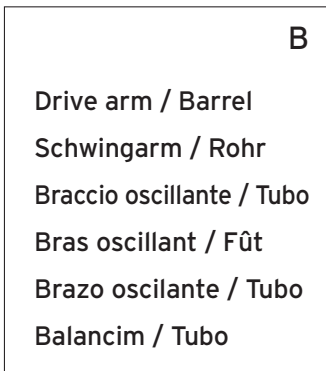
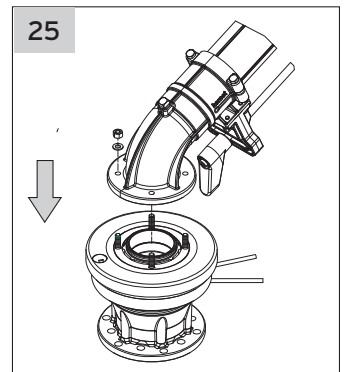
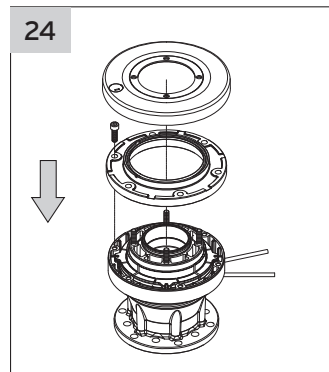
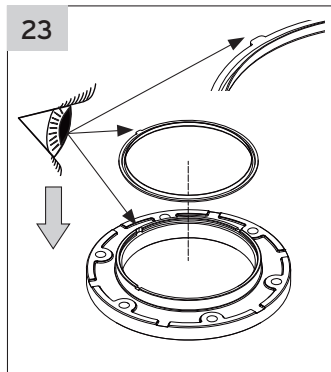
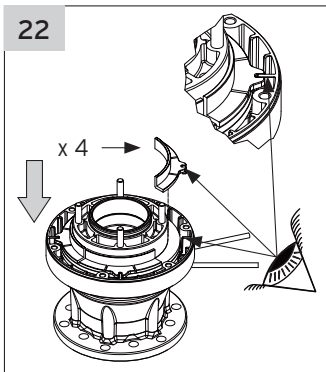
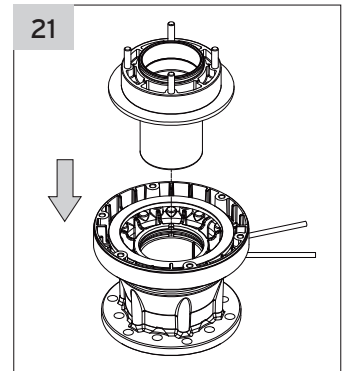
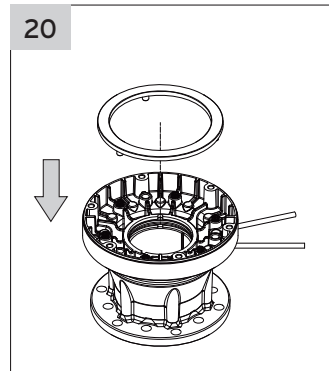
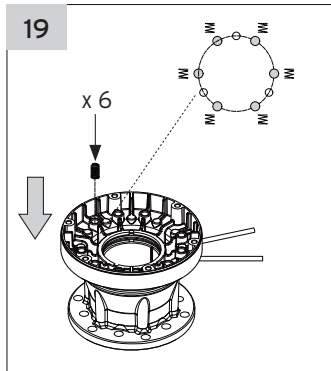
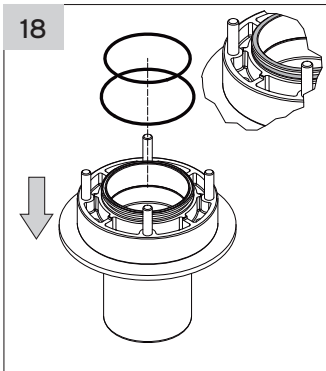
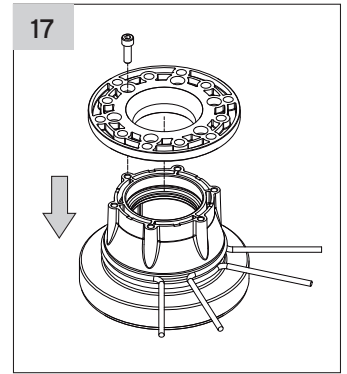
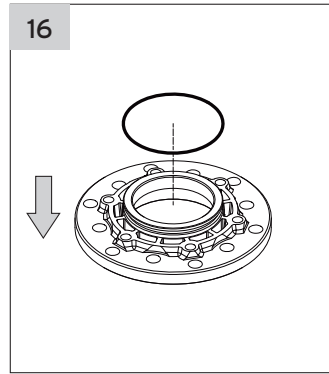
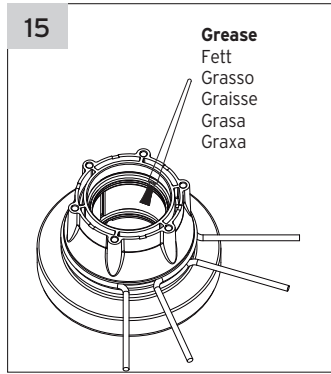
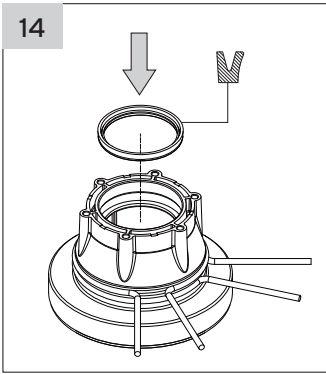

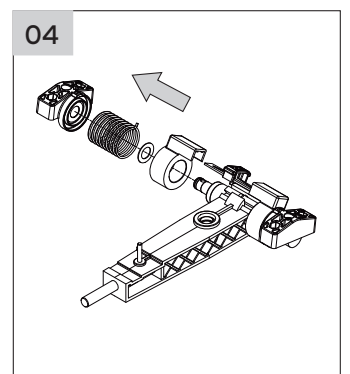
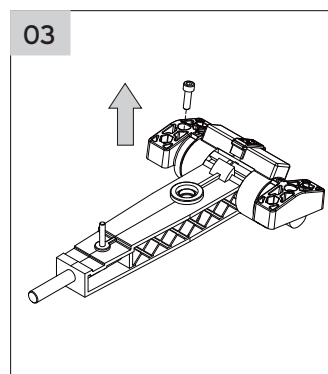
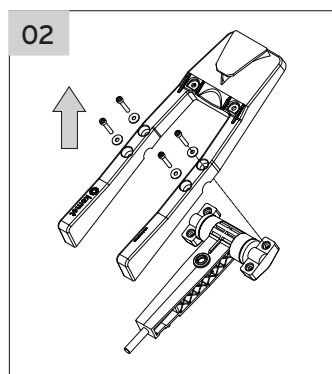
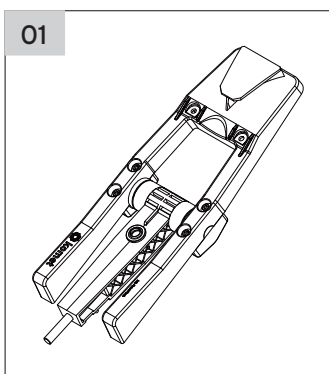
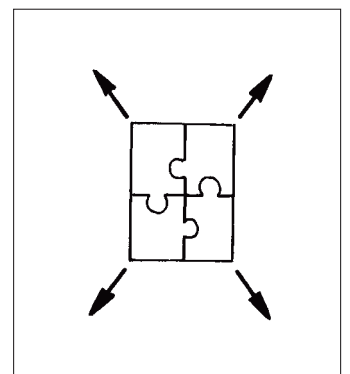
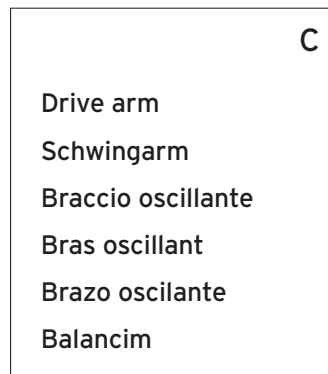
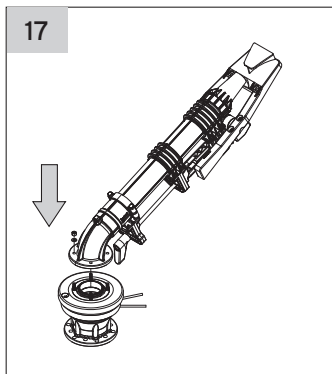
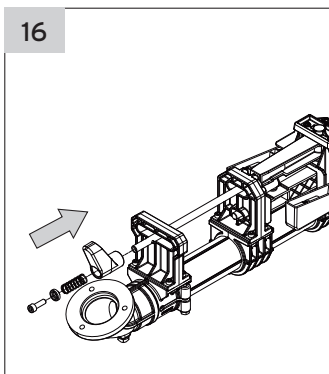
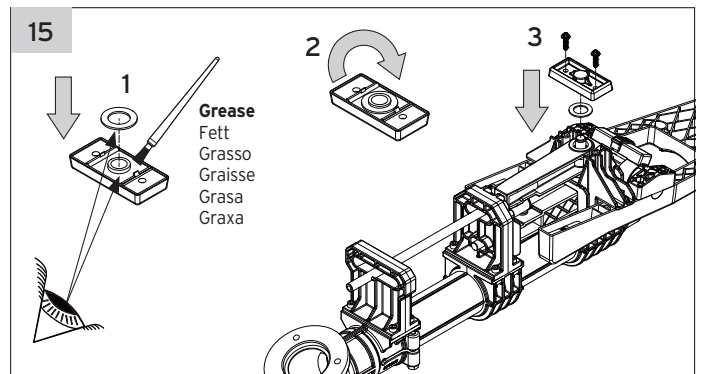
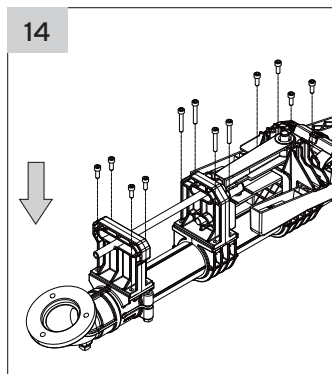
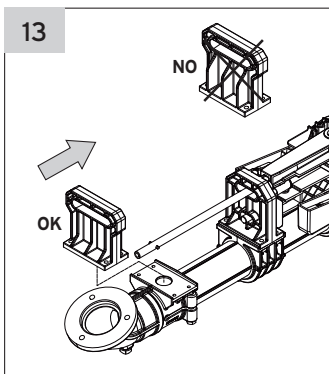
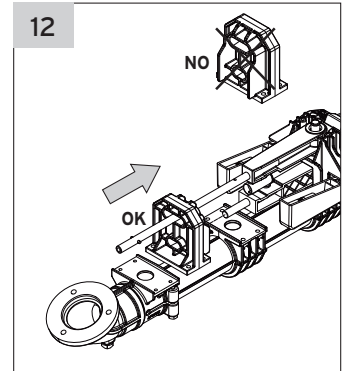
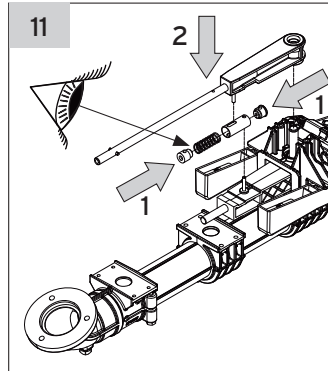
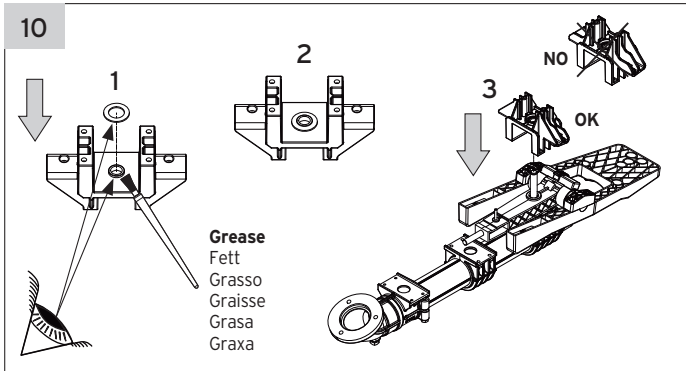
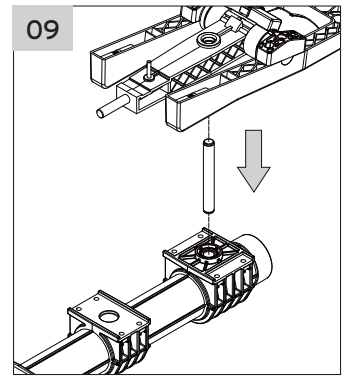
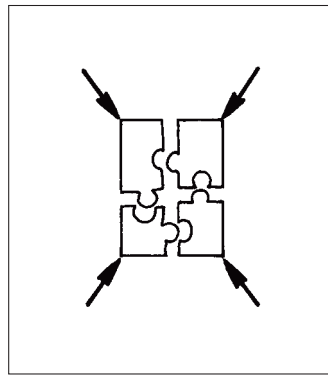
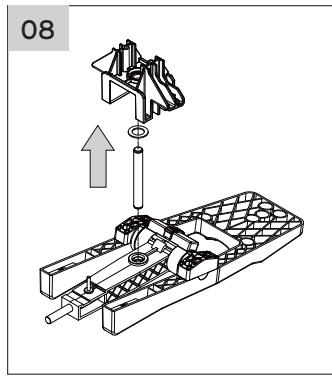
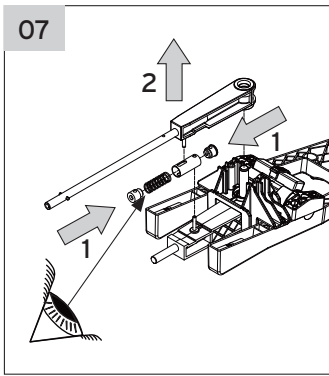

05

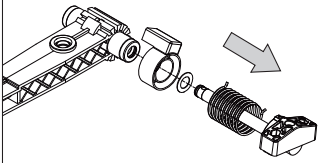

06

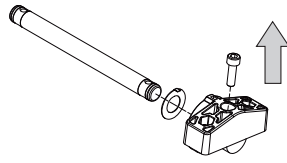

08

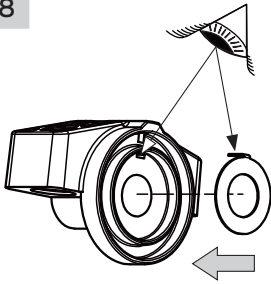

09

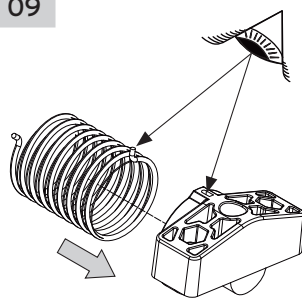

10

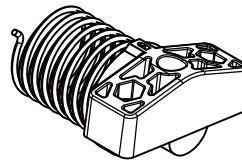

11

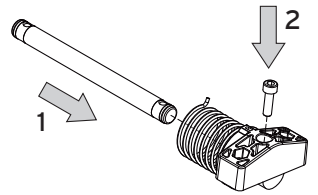

12

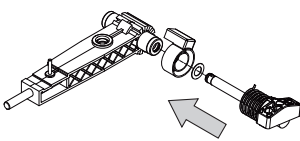

13

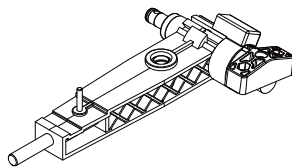

14

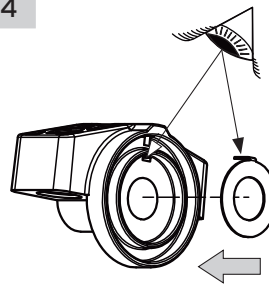

15

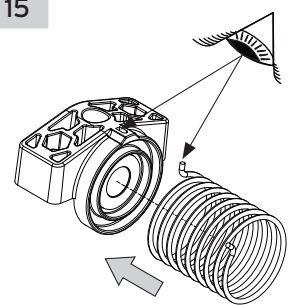

16

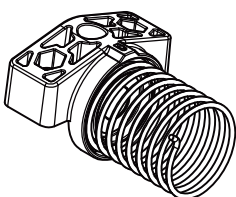

17

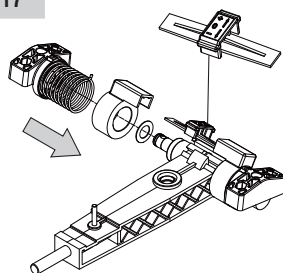

18

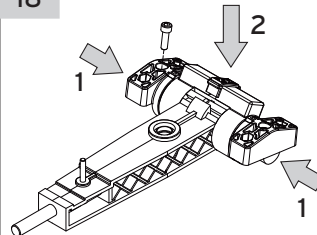

19

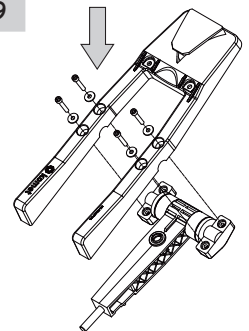

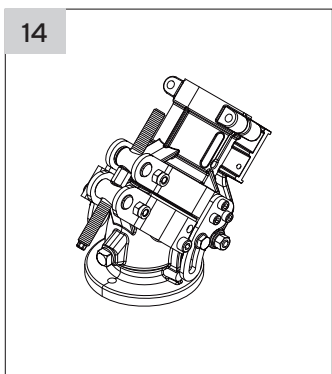
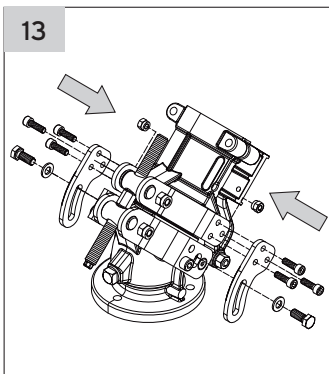
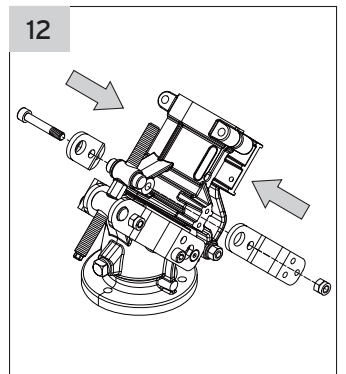
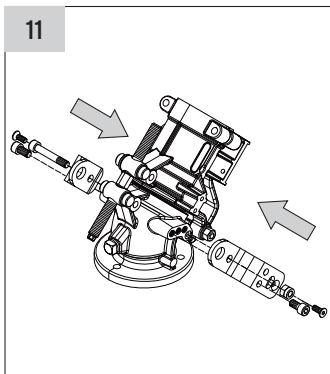
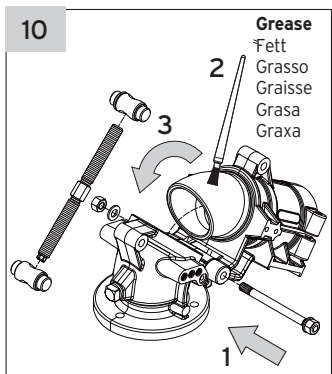
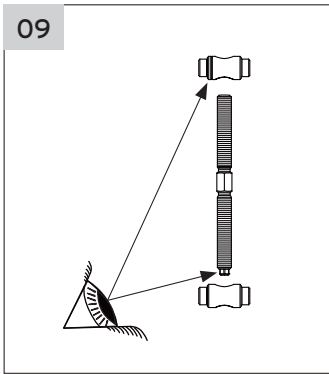
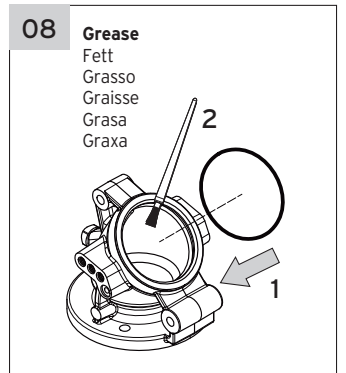
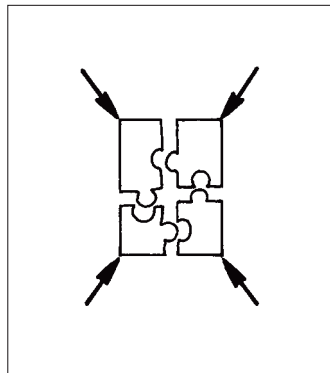
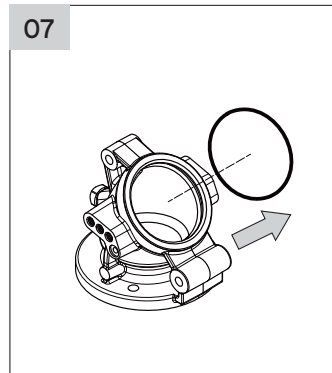
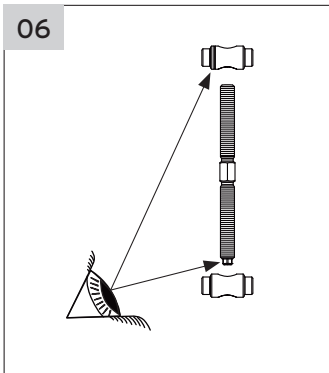
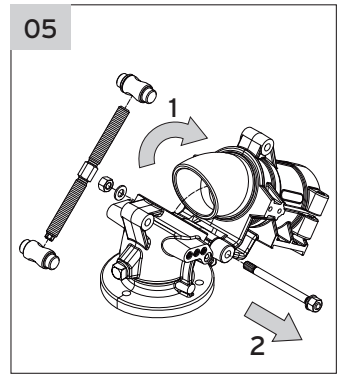
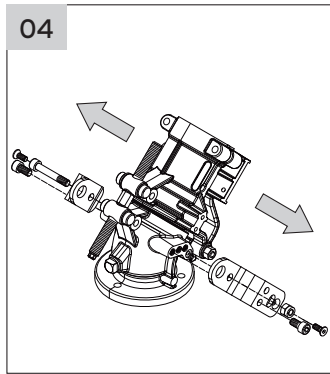
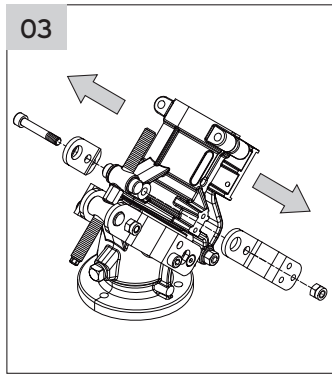
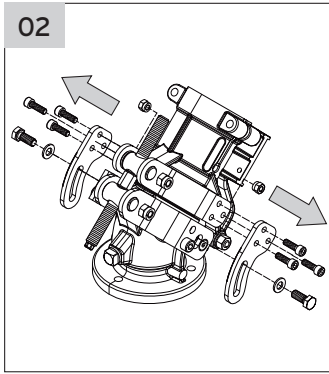
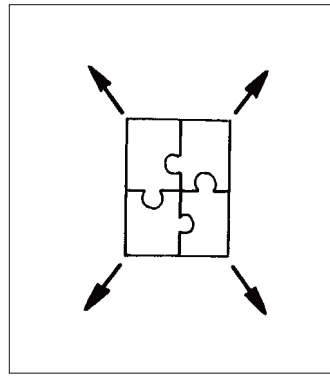
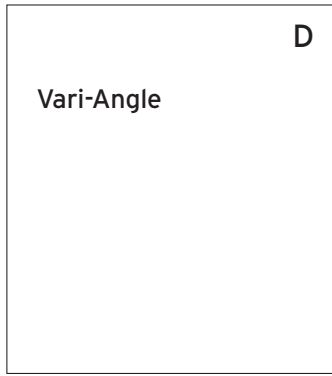
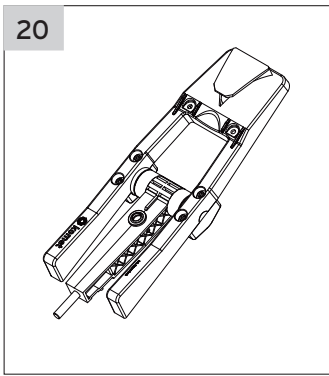

D  
Vari-Angle

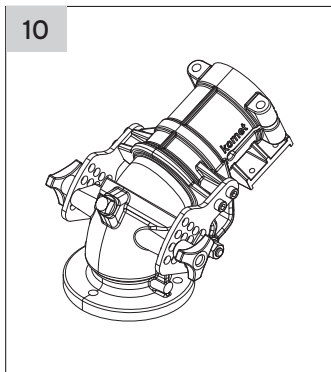
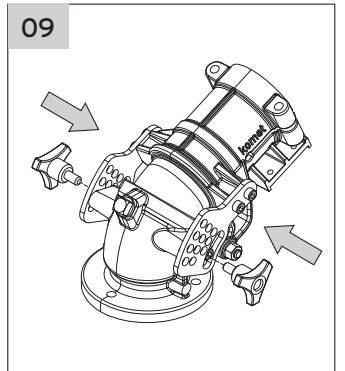
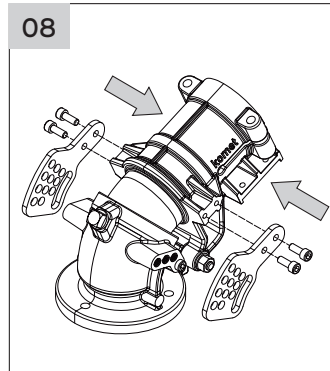
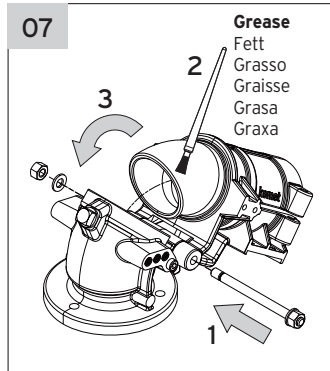
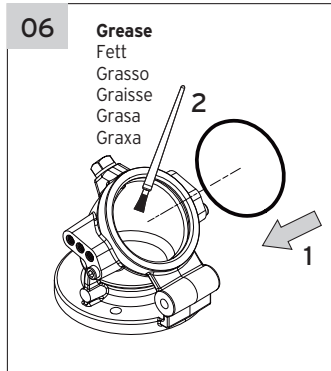
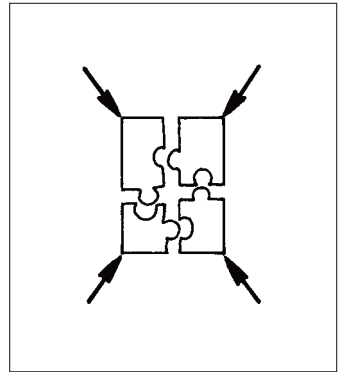
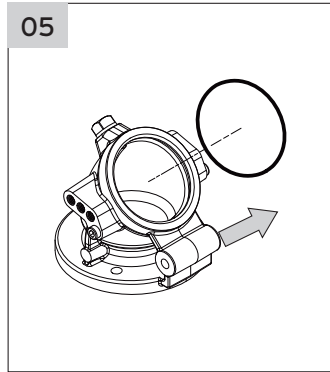
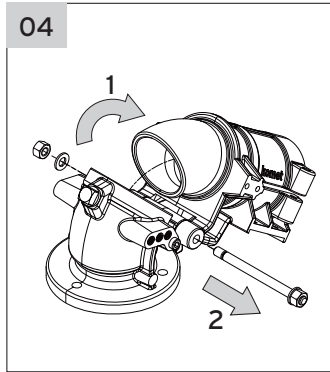
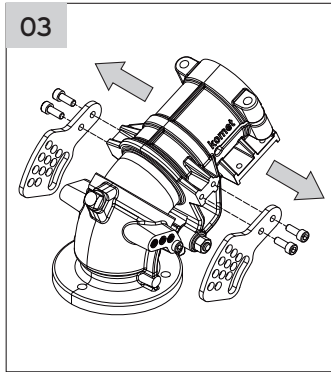
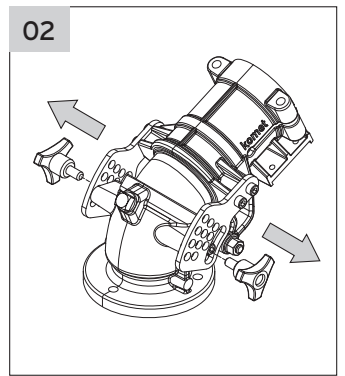
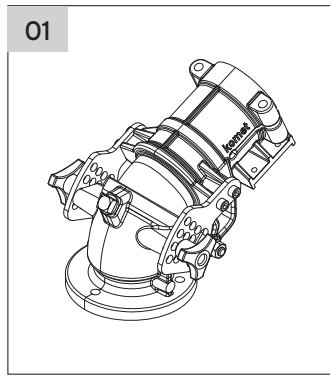
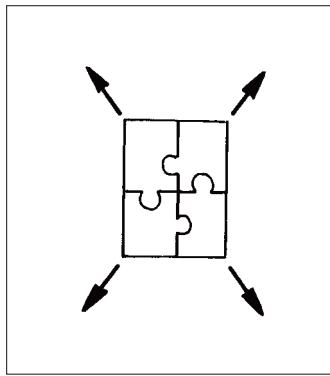

Lock for transport  
Transportsicherung  
Arresto per trasporto  
Fixation pour transport  
Bloqueo de transporte  
Trava de transporte

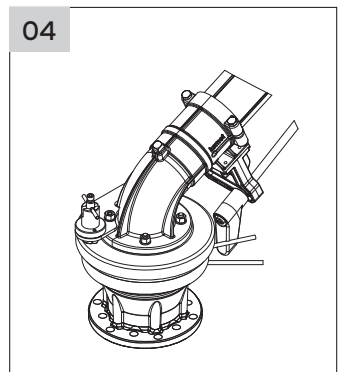
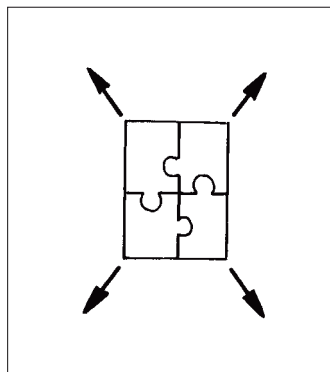
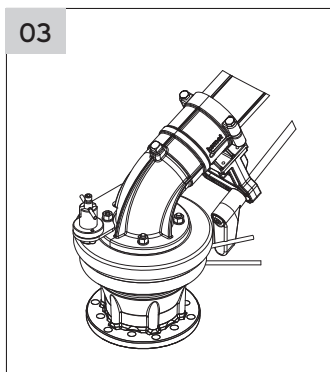
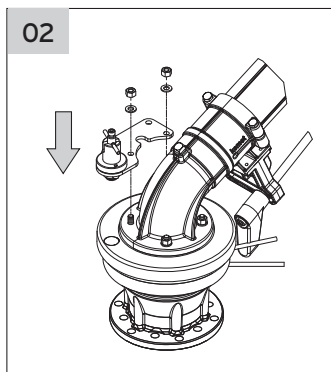
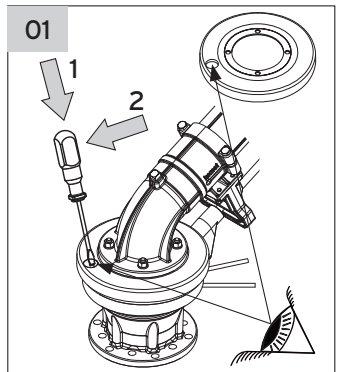
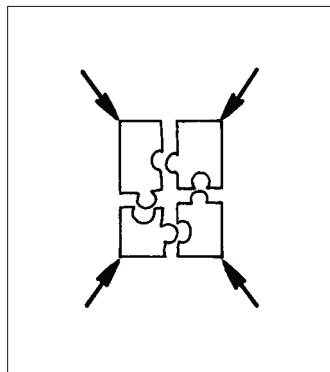



05

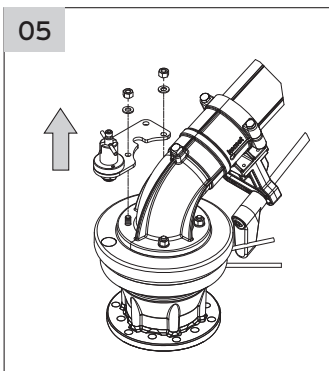

06

