



Duplex circolare 25°

Cod. 10158

Attacco a vite femm. Fem. connection screw Raccord fileté fem. Conexión con tornillo fem. Anschluss mit Schraubenmutter		
Inch	2"	
Peso netto Net weight Poids net Peso neto Net gewicht		
kg	2,630	
Dim. imb. per 4 irrigatori Size/pack. for 4 rainguns Dim./emb pour 4 arros. Dim./emb. para 4 aspers. Verpackungsausmaße für 4 Wasserbestäuber		
cm	57x27x38	

Irrigatore di media portata a funzionamento circolare. E' dotato di ugelli intercambiabili e di un rompigiuglio a penetrazione regolabile, che assicura una precipitazione fine e uniformemente distribuita. Tra le sue caratteristiche spiccano in particolare la grande semplicità dei meccanismi e la straordinaria versatilità d'impiego. E' adatto per qualsiasi tipo di impianto e si presta per terreni di qualsiasi natura ed estensione.

Sprinkler of medium discharge for complete operation. It is equipped with different interchangeable nozzles and an adjustable jet-breaker providing and uniform distribution of water all over the irrigated area. The great simplicity and the large versatility are amongst its main features, in fact, it can be applied to all kinds of land and cultivation.

Arroseur circulaire à débit moyen. Il est fourni de buses interchangeables et d'un brise-jet réglable qui assure une pluie très fine et régulière sur toute la surface arrosée. Très importantes parmi ses caractéristiques sont la rationalité des mécanismes et la versatilité d'emploi.

Aspersor de media capacidad con funcionamiento circular, a regulación. Está provisto de toberas intercambiables y de un quebrachorro con regulación de penetración, que asegura una precipitación sutil y uniformemente distribuida. Entre sus características sobresalen especialmente la gran simplicidad de los mecanismos y la extraordinaria versatilidad de empleo. Es apto para cualquier tipo de instalación y se conviene para tierras de cualquier naturaleza y extensión.

Mitteldruck - Beregner mit mittlerer Tragweite. Funktioniert rotierend Kreisbildend. Er hat einen speziellen regulierbaren Strahlbrecher. Geeignet um Keimlinge, Gemüsegelder und frisch besäte Felder zu beregnen. Mit diesem Beregner sind feste wie mobile Anlagen möglich.

BOCCAGLI DISPONIBILI - AVAILABLE NOZZLES - BUSES DISPONIBLE - TOBERAS DISPONIBLE - DÜSEN SIND VERFÜGBAR
 Ø 10 + 22 mm

U Diametro ugello Nozzle diameter Diamètre de la buse Diámetro de la tobera Durchmesser der Hauptdüse	P Pressione Pressure Pression Presión Wasserdruck im Beregner	G Gittata Jet length Portée Chorro Tragweite	Q Portata Capacity Débit Capacidad Kapazität		○ Dati relativi ad 1 irrigatore Values for a single sprinkler Données pour 1 arros. tout seul Datos para cada rociador technische Daten für Einzelberegner					□ Disposizione in quadrato Square pattern Arroseur en carré Aspersores en cuadrado Quadratische Disposition				△ Disposizione in triangolo Triangular pattern Arroseur en triangle Aspersores en triángulo Rechteckposition			
			S Superficie irrigata Irrigated area Surface arrosée Superficie irrigada Beregnete Fläche	I Intensità oraria Rainfall per hour Pluviométrie horaire Intensidad horaria Wassermenge pro Stunde	D Distanza fra 2 ali piovane contigue Distance between 2 contiguous pipelines Distance entre 2 conduites de pluie Distanza entre 2 alas de lluvia contiguas max. Distanz zwischen zwei nebeneinanderliegenden Rohren	S Superficie irrigata Irrigated area Surface arrosée Superficie irrigada Beregnete Fläche	I Intensità oraria Rainfall per hour Pluviométrie horaire Intensidad horaria Wassermenge pro Stunde	D Distanza irrigatori sull'ala piovana Distance of the sprinklers on the pipeline Distance des arroseurs sur la conduite de pluie Distanza de los aspersores sobre el ala de lluvia max. Distanz zwischen nebeneinanderliegenden Rohren	D1 Distanza fra 2 ali piovane contigue Distance between 2 contiguous pipelines Distance entre 2 conduites de pluie Distanza entre 2 alas de lluvia contiguas max. Distanz zwischen zwei nebeneinanderliegenden Rohren	S Superficie irrigata Irrigated area Surface arrosée Superficie irrigada Beregnete Fläche	I Intensità oraria Rainfall per hour Pluviométrie horaire Intensidad horaria Wassermenge pro Stunde						
			m ²	mm/h	m	m ²	mm/h	m	m	m ²	mm/h						
12 8	1,5	20	159	9,5	1256	7,5	28	784	12,1	34	30	1020	9,3				
	2	23	184	11,0	1662	6,6	32	1024	10,7	40	34	1360	8,0				
	3	27	224	13,4	2289	5,8	38	1444	9,3	46	40	1840	7,3				
	4	30	259	15,5	2826	5,4	42	1764	8,8	52	45	2340	6,6				
14 8	2	25	230	13,8	1962	7,0	35	1225	11,2	43	37	1591	8,7				
	3	29	280	16,8	2640	6,3	41	1681	9,9	50	43	2150	7,8				
	4	32	325	19,5	3217	6,0	45	2025	9,6	55	48	2640	7,4				
	5	34	364	21,8	3629	6,0	48	2304	9,5	59	51	3009	7,2				
16 8	2	27	282	16,9	2289	7,3	38	1444	11,7	46	40	1840	9,2				
	3	31	344	20,6	3017	6,8	43	1849	11,1	53	46	2438	8,4				
	4	34	399	23,9	3629	6,5	48	2304	10,4	59	51	3009	7,9				
	5	37	446	26,7	4298	6,2	52	2704	9,9	64	55	3520	7,6				
18 8	2	28	343	20,6	2461	8,3	39	1521	13,5	48	42	2016	10,2				
	3	33	434	26,0	3419	7,6	46	2116	12,3	57	49	2793	9,3				
	4	36	506	30,3	4069	7,4	51	2601	11,6	62	54	3348	9,0				
	5	40	561	33,6	5024	6,7	56	3136	10,7	69	60	4140	8,1				
20 8	2	29	411	24,6	2640	9,3	41	1681	14,6	50	43	2150	11,4				
	3	34	520	31,2	3629	8,5	48	2304	13,5	59	51	3009	10,3				
	4	38	606	36,3	4534	8,0	53	2809	12,9	65	57	3705	9,8				
	5	43	657	39,4	5805	6,7	60	3600	10,9	74	64	4736	8,3				
22 8	3	34,5	590	35,4	3737	9,5	48	2304	15,3	60	52	3120	11,3				
	4	39	682	40,9	4775	8,6	55	3025	13,5	67	58	3886	10,5				
	5	44	766	45,9	6079	7,6	62	3844	12,0	76	66	5016	9,1				
	6	46,5	839	50,3	6789	7,4	65	4225	11,9	80	70	5600	9,0				

A SETTORI cod. 10137

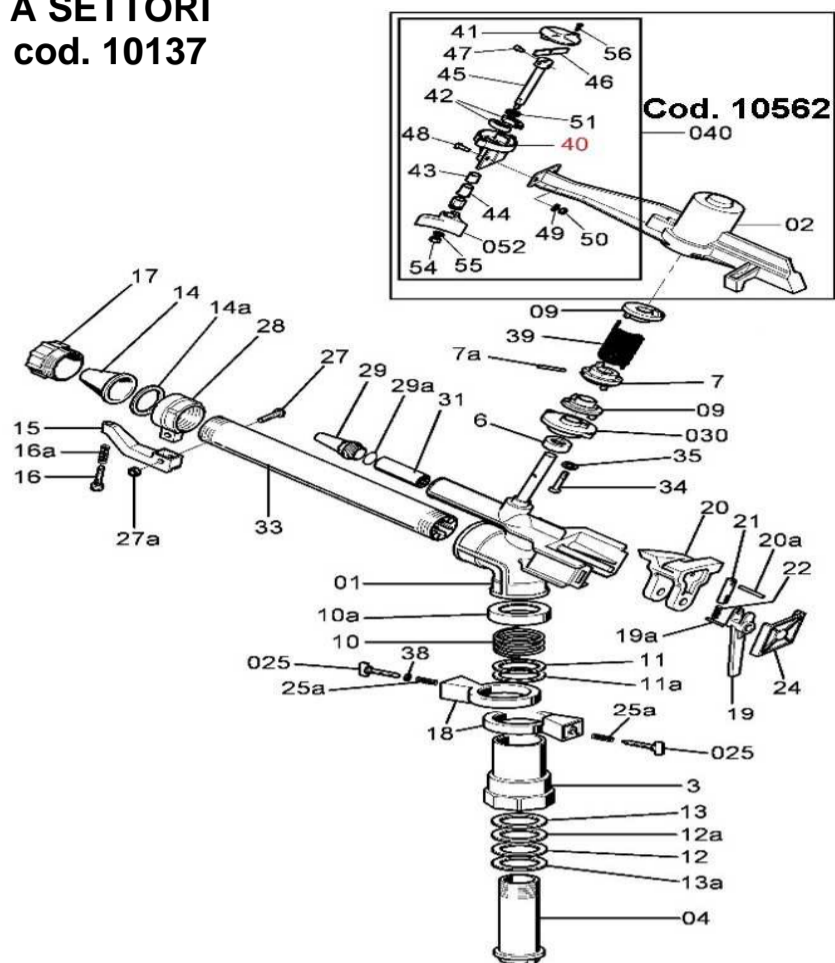

CIRCOLARE cod. 10158

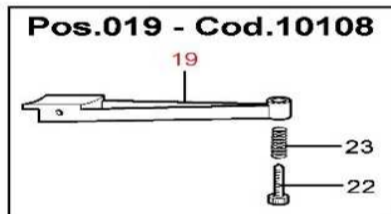
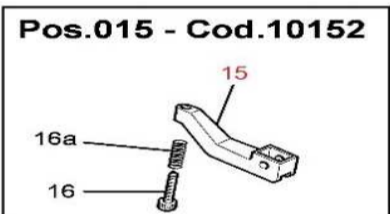
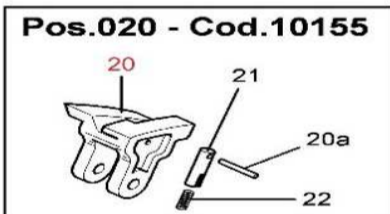
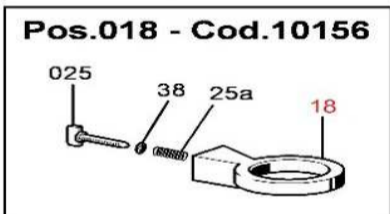
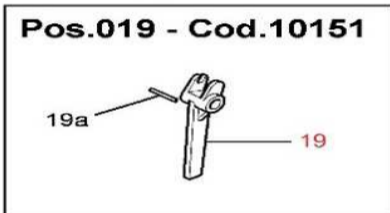
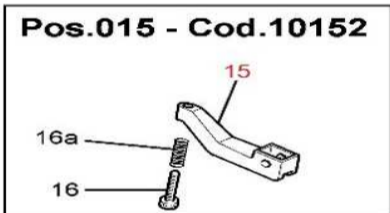
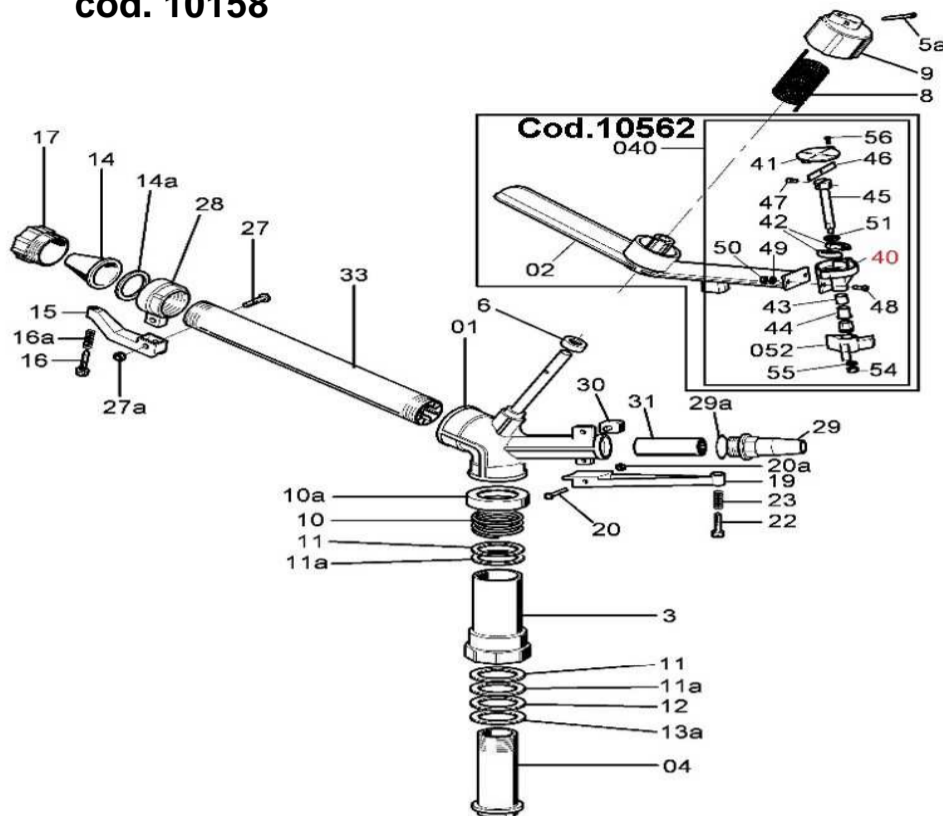

Duplex a settori

CODICE CODE N°	POSIZIONE POSITION
10153	01
10563	02 - new
30793	3
10179	04
20193	6
30797	7
30798	7a
10422	09
30802	10
30803	10a
30804	11
30805	11a
20183	12
30805	12a
30804	13
3010496	13a
30566	14
30567	14a
10152	015
30359	16
30374	16a
30211	17
10156	018
10151	019
30813	19a
10155	020
30815	20a
30817	22
30819	24
10430	025

CODICE CODE N°	POSIZIONE POSITION
30821	25a
30825	27
30726	27a
30827	28
30828	29
30678	29a
10239	030
30291	31
20105	33
30443	34
30557	35
3010182	38
3010270	39
10562	040 - new
3010935	41 - new
3010908	42 - new
3010939	43 - new
3010940	44 - new
10645	045 - new
3010906	46 - new
3010905	47 - new
30783	48 - new
30532	49 - new
30270	50 - new
3010649	51 - new
10352	052 - new
30501	54 - new
30587	55 - new
3010279	56 - new

Duplex circolare

CODICE CODE N°	POSIZIONE POSITION
10177	01
10564	02 - new
30793	3
10179	04
30371	5a
20193	6
30971	8
30972	9
30802	10
30803	10a
30804	11
30805	11a
20183	12
3010496	13a
30566	14
30567	14a
10152	015
30359	16
30374	16a
30211	17
10108	019
301013	20
30726	20a
30359	22
30374	23
30825	27
30726	27a
30827	28
30828	29
30678	29a

CODICE CODE N°	POSIZIONE POSITION
30369	30
30291	31
20105	33
10562	040 - new
3010935	41 - new
3010908	42 - new
3010939	43 - new
3010940	44 - new
10645	045 - new
3010906	46 - new
3010905	47 - new
30783	48 - new
30532	49 - new
30270	50 - new
3010649	51 - new
10352	052 - new
30501	54 - new
30587	55 - new
3010279	56 - new