

Technical Manual

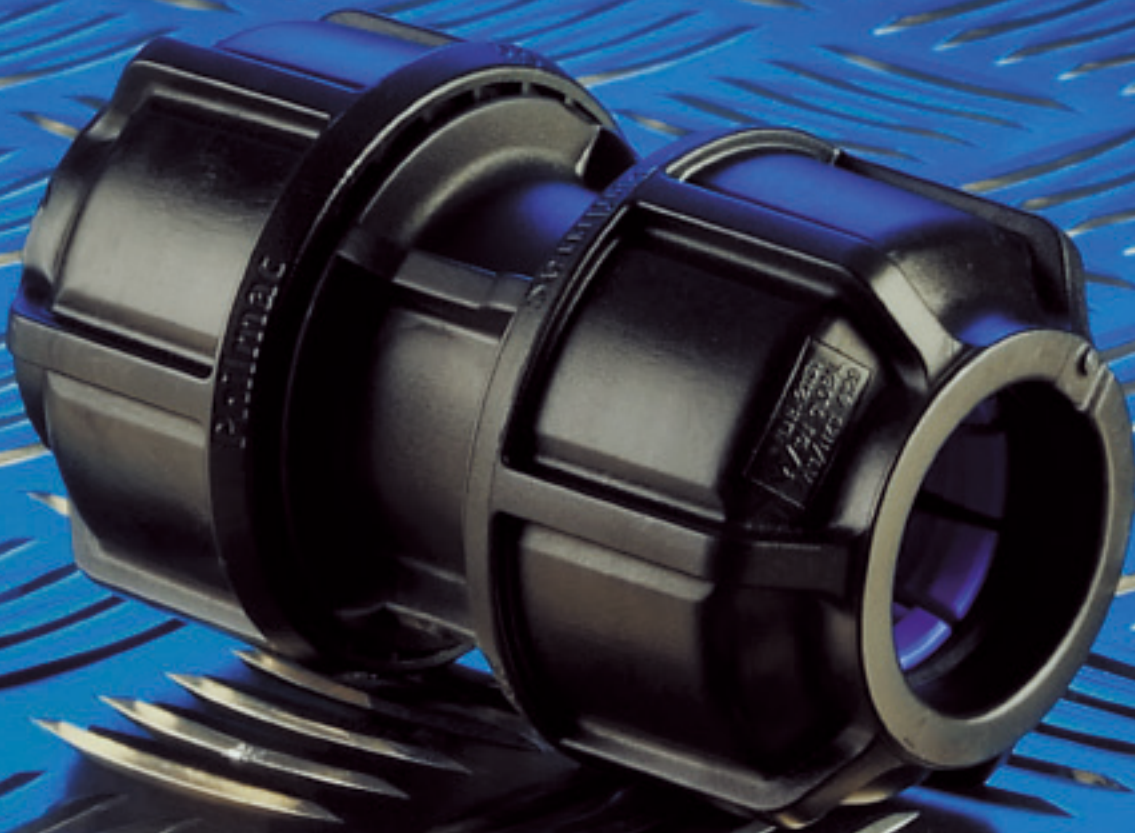



Philmac is well renowned for quality products and services.

Philmac manufactures pipe fittings and valves under a Quality Assurance System assessed and approved to ISO 9001.

Philmac has a NATA accredited laboratory and tests fittings and valves to international and national standards. Third party accreditation is carried out by SAI Global.

CONTENTS

Introduction	2
Benefits	2
Standards	3
Installation Instructions	4
System Design Considerations	7
Materials & Components	8
Principals of Operation	8
Range Dimensions & Weights	9
Product Specification	18



Disclaimer

Please note that the information, opinions, recommendations and advice given in this manual are supplied only to provide an improved understanding of the technical aspects of fitting systems.

So far as the law allows, Philmac Pty Ltd will not accept liability in respect of any loss or damage of any kind claimed to arise as a result of reliance upon any information claimed in this manual.

Please refer to our Terms and Conditions of sale.

INTRODUCTION

Philmac, Australia's premier manufacturer of plastic compression fittings for polyethylene pipelines is proud to release 3G Metric™ – our third and very latest generation of fittings to connect metric sized poly pipe.

Having taken international markets by storm since its release in 2005, 3G Metric™ is now set to make metric poly pipe connections in Australia easier than ever before. The culmination of years of research & development and utilisation of cutting-edge manufacturing technology and stringent testing, this new range of fittings is smaller, tougher and faster to use than ever before. And, its 100% compatible with Australia's number one fitting to join rural poly pipe, Philmac Rural.

Designed to make the job at hand so much easier, the 3G Metric™ plastic compression fitting is the product of Philmac's unrelenting commitment to continuous improvement and a culture based on innovation and ingenuity.

BENEFITS

Fast and easy installation

- **Slide & Tighten® technology:** 3G Metric™ incorporates all the benefits of Philmac's unique Slide & Tighten® technology. No pipe preparation is needed and no force is required to push the pipe past the seal, so installation couldn't be faster or easier. Simply insert the pipe into the fitting until the stop is felt, and then tighten the nut. Assembly is so easy you can even do it under live conditions. No special tools are required, and there is no need to disassemble the fitting before use because the 3G Metric™ compression fitting is supplied pre-assembled and ready to use.
- **Compact design:** The size of the new Philmac 3G Metric™ compression fitting has been kept to a minimum, making the fitting ideal to use in confined areas. In addition to making connections with minimal turns of the nut, the design and size of the fitting means that in installations taking place between two fixed points, the manipulation of the pipe into the fitting becomes easy.
- **Easy disassembly:** The fitting has been designed so the collet is released as soon as the nut is backed off, making disassembly easy.

Complete security

- **Dynamic sealing method:** The mechanical advantage of the nut thread compresses the seal into position.
- **Visual stop:** The flange on the body of Philmac's 3G Metric™ compression fitting provides a visual stop to indicate when the nut is fully tightened. This removes any uncertainty from the installation process.
- **No loose components:** If the nut is removed there is no danger of losing components, as the collet and seal are retained in the body of the fitting. Losing components in the trench becomes a thing of the past.
- **Designed to minimise pipe twist:** The fitting has been designed to minimise pipe twist as the nut is tightened. Maximum pipe twist is approximately a quarter turn compared to one and a half turns with many other fittings. Pipe twist can impact on not only the connection you have just made but also on the connection at the other end of the line.
- **Approvals:** Philmac 3G Metric™ is WaterMark approved and has WSAA appraisal.

High performance

- **Made from advanced thermoplastic materials:** 3G Metric™ is manufactured from lightweight high performance thermoplastic materials with outstanding impact, UV, chemical and corrosion resistance. The material is non-toxic and taint-free.
- **Rated to 1600 kpa:** 3G Metric™ is pressure rated to 1600 kpa (PN16) to meet the needs of high pressure systems.
- **50 year+ design life:** Built to withstand the toughest conditions to ensure longevity and durability, 3G Metric™ has a 50 year+ design life.

Complete coverage

- **Wide range:** The new 3G Metric™ range is comprehensive: straight and reducing joiners, tees, elbows, end connectors and caps ranging from 16mm to 63mm.
- Philmac 3G Metric™ also incorporates a range of dedicated recycled water fittings and poly to copper connections for fast and simple connection to both PE and copper pipe.



STANDARDS

Philmac 3G Metric™ is a complete range of mechanical fittings designed to make connections simple when joining metric PE pipes.

Philmac 3G Metric's innovative design comprises the following product mix;

Product Description	Size (mm)	Maximum Operating Pressure (KPa)
Compression fittings (PE x PE/PI BSP/MI BSP)	16-63	1600 (16 bar)
Compression fittings PE x (UTC)	16-63 (15-61)	1250 (12.5 bar)
Compression fittings PE x (Copper)	16-32 (1/2", 3/4")	1600 (16 bar)
Tapping saddles	32-110	1600 (16 bar)
Accessories - Spanners	20-63	

Philmac 3G Metric™ is designed to comply with the requirements of the following standards:

AS/NZS4129 & 14236

Fittings for polyethylene pressure pipe systems.

AS/NZS 4020

Products for use in contact with water intended for human consumption with regards to their effect on the quality of water.

AS3688

Water supply - copper and copper alloy body compression and capillary fittings and threaded-end connectors.

ISO7.1 & BS21

Pipe threads where pressure joints are made on the threads.

PE Pipes - AS/NZS4130, ISO4427, EN12201 (formally BS6572 & BS6730)

Polyethylene pipes for pressure applications.

Copper Pipes - AS1432

Copper tubes for plumbing, gas fitting and drainage applications.

Note: Philmac 3G Metric™ is also suitable for use with pipes manufactured according to various overseas and international standards. Please consult Philmac Technical Services for information.

INSTALLATION INSTRUCTIONS – POLY



1. Cut Pipe Square

Cut the pipe square. There is no need to prepare the pipe end. Chamfering or lubrication is not required.



2. Ready to Use Position

The fitting is pre-assembled and ready to use, however always ensure the nut is fully relaxed and 2 threads are showing before inserting the pipe.



3. Pipe Insertion

Insert the pipe until the stop is felt.



4. Nut Tightening

The nut should be tightened by hand and then firmly with a wrench. Tighten the nut all the way to the flange on the body of the fitting.



5. Fully Installed

Fitting is now fully installed.



6. Disassembly

To disassemble the fitting simply loosen the nut using a wrench until 2 threads are showing. Pipe will be released and can simply be pulled out of the fitting.

* **Slip Couplings** – To ensure adequate insertion depth, witness mark the pipes to the flange on the fitting. Then insert the pipe to the correct depth.

Note: Philmac recommends the use of PTFE tape on BSP threads to ensure a positive seal.

INSTALLATION INSTRUCTIONS – POLY TO COPPER (ASI432)



1. Cut Pipe Square

Cut pipe square. Ensure the pipe is free from sharp burrs. Chamfering or lubrication is not required.



2. Ready to use position

The fitting is pre-assembled and ready to use.



3. Pipe insertion

Insert the pipe and push it past the olive.



4. Nut tightening

The nut should be tightened firmly with a wrench.

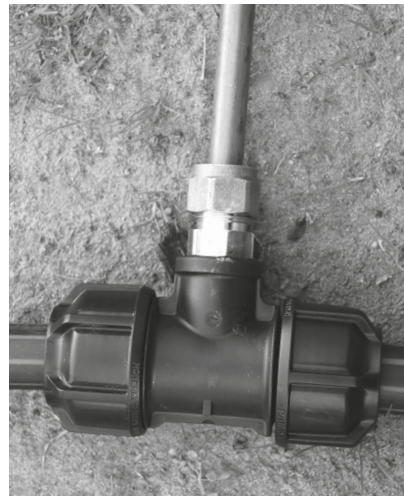

5. Fully installed

The fitting is now fully installed.



6. Disassembly

To disassemble the fitting, simply loosen the nut using a wrench. Pipe will be released and can be pulled out of the fitting.

Note: Installation instructions apply to the copper end of a 3G x Copper fitting.

INSTALLATION INSTRUCTIONS – POLY TO UTC

(UTC joins PVC, Copper, Galvanised Iron, Stainless Steel, Lead, Steel and PE Pipes)



1. Cut Pipe to Length

The fitting is pre-assembled and ready to use. Cut pipe square and to length using the flange on the central body as a guide. Ensure the end of connecting pipe is undamaged and clean.



2. Ready to Use Position

To ensure adequate insertion depth, witness mark the pipe to the back of the flange. If conditions permit a marker pen can be used or alternatively use of a thumb is suitable.



3. Pipe Insertion

Insert the pipe to the correct depth. Always ensure the nut is backed off and 3 threads are showing. Pipes at the top end of the fitting tolerance may require 5 threads showing.



4. Nut Tightening

Tighten nut firmly with a wrench. Nut will not butt against the body flange when the pipe size is at the top end of the fitting tolerance.



5. Fully Installed

The fitting is fully installed when the nut cannot be tightened any further with reasonable force.



6. Disassembly

Unscrew the nut with a wrench. Pipe will be released and can be pulled out of the fitting.

Note: Installation instructions apply to the UTC® end of a 3G x UTC® fitting or the UTC® ends of a UTC® x UTC® fitting.

SYSTEM DESIGN CONSIDERATIONS

Projected life of Compression fittings

Whilst Philmac 3G Metric™ conforms to institutionalised specifications written to have a minimum life of 50 years, its compression fittings are intentionally developed to exceed the expectations of these specifications.

Head losses

The following table offers a guide in estimating head losses in PE pipe systems based on the conveyance of water. Use the following formula to estimate this head loss;

$$L = F \times D$$

where F = fitting constant

D = pipe inner diameter (m)

L = head loss based on equivalent pipe length (m)

Fitting	Fitting Constant(F)
90° elbow	30
90° tee - straight through	12
90° tee - side branch	60

Resistance to Impact

The thermoplastic materials used in the Philmac 3G Metric™ fitting have excellent impact properties.

Abrasion Resistance

Philmac 3G Metric™ is suitable for the transportation of abrasive slurries and will withstand normal conditions found in urban, mining, industrial, rural water and waste water systems.

Weathering

The materials used contain pigments to provide excellent protection to degradation due to ultra-violet radiation. Continuous use of the Philmac 3G Metric™ fitting in systems above ground is therefore permissible without additional protection.

There are generally two types of PE pipe fittings; mechanical and thermofusion. Philmac 3G Metric™ is a range of mechanical fittings that offers three distinct advantages over thermofusion fittings;

- **More economical**
- **Quick and easy installation**
- **Quick and easy revision to installation**

This section highlights engineering considerations when designing a PE pipe system with Philmac 3G Metric™.

Electrolytic Corrosion

Philmac 3G Metric™ is non magnetising and does not cause electrolytic deterioration.

Thermal Insulation

Polypropylene has natural thermal insulation of 2000 times over copper and 200 times over steel.

Light Transmission

The all black Philmac 3G Metric™ does not transmit light, thus protecting the water quality in potable water pipelines from growth of micro organisms.

Effect on Water

Philmac 3G Metric™ does not impart to water any odour, taste, colour, or any constituents in concentrations that could be injurious to health.

Fluids other than Water

Philmac 3G Metric™ may convey a wide variety of fluids. The following table is provided as a guide only for the compatibility of various chemicals to Philmac 3G Metric™. Contact Philmac for advice on specific applications.

Temperature

Philmac UTC Compression fittings are designed for cold water applications only. Exposure to elevated temperatures has a significant impact on the lifetime of the fittings. All projected lifetimes are based on an operating temperature of 23 degrees Celsius.

CHEMICAL RESISTANCE

Chemical	Satisfactory	Not Satisfactory
Air	▲	
Ammonium Hydroxide	▲	
Alcohol	▲	
Acetone		▲
Auto Transmission Fluid	▲	
Antifreeze	▲	
Benzene		▲
Butane	▲	
Calcium Salts	▲	
Caustic Soda (40% aqueous)	▲	
Cresol		▲
Citric Acid (10% aqueous)	▲	
Copper Salts	▲	
Ethylene Alcohol	▲	
Ethyl Glycol	▲	
Diesel	▲	
Formic Acid		▲
Gasoline		▲
Hydrochloric Acid		▲
Kerosene		▲
Mineral Oils	▲	
Methane	▲	
Methylene Chloride		▲
Nitric Acid		▲
Petroleum Oils	▲	
Sewerage	▲	
Sodium Cyanide	▲	
Sulphuric Acid		▲
Toluene		▲
Turpentine		▲
Transformer Oil	▲	
Zinc Salt Solution	▲	

Note: Fluid Temperature = 20°C

MATERIALS & COMPONENTS

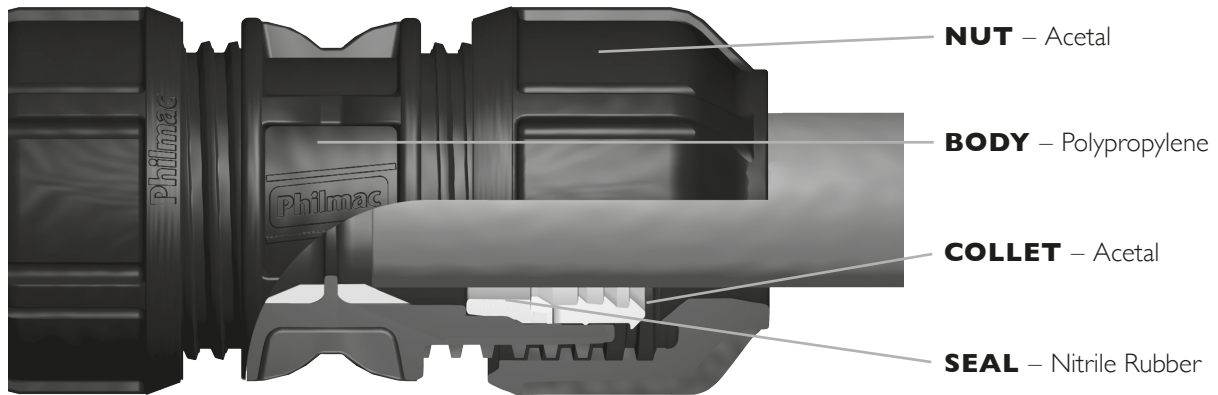

PRINCIPALS OF OPERATION

FULLY OPEN

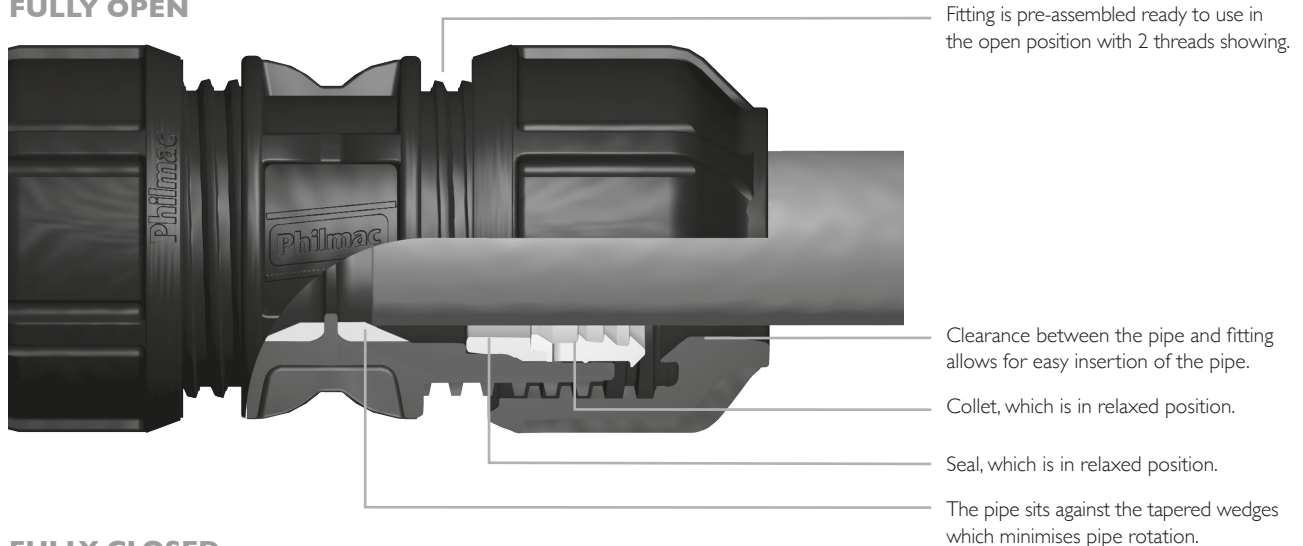

FULLY CLOSED

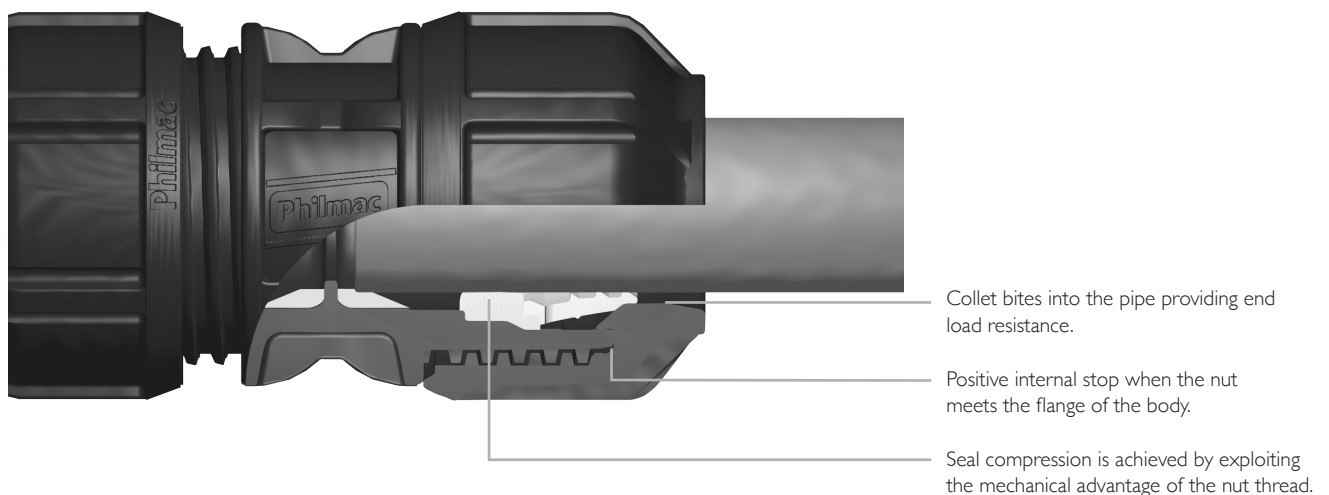

RANGE DIMENSIONS & WEIGHTS



RANGE DIMENSIONS & WEIGHTS

JOINERS (Metric X Metric)

Size	Part No.	Dimensions mm.			kg.
		S	D	L	Wt
16 x 16	70711100	9	40	76	0.03
20 x 20	70712200	10	47	90	0.08
25 x 25	70713300	11	55	97	0.12
32 x 32	70714400	14	67	118	0.20
40 x 40	70715500	18	81	136	0.33
50 x 50	70716600	24	94	161	0.52
63 x 63	70717700	29	110	182	0.76

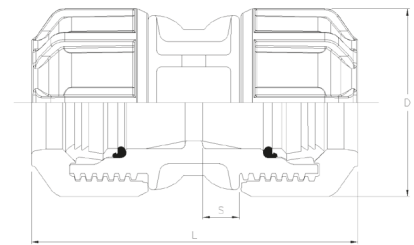

SLIP JOINERS (Metric X Metric)

Size	Part No.	Dimensions mm.			kg.
		D	L	Wt	
20 x 20	70701220	47	90	0.08	
25 x 25	70701330	55	97	0.12	
32 x 32	70701440	67	118	0.20	
40 x 40	70701550	81	136	0.33	
50 x 50	70701660	94	161	0.52	
63 x 63	70701770	110	182	0.76	

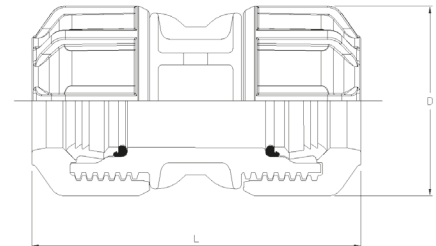

REDUCING JOINERS (Metric X Metric)

Size	Part No.	Dimensions mm.					kg.
		S	S1	D	D1	L	Wt
20 x 16	70712100	10	9	47	40	83	0.06
25 x 16	70713100	11	9	55	40	87	0.06
25 x 20	70713200	11	10	55	47	94	0.10
32 x 20	70714200	14	10	67	47	110	0.14
32 x 25	70714300	14	11	67	55	108	0.16
40 x 25	70715300	18	11	81	55	125	0.24
40 x 32	70715400	18	14	81	67	128	0.28
50 x 25	70716300	24	11	94	55	141	0.34
50 x 32	70716400	24	14	94	67	150	0.38
50 x 40	70716500	24	18	94	81	149	0.44
63 x 32	70717400	29	14	110	67	167	0.51
63 x 40	70717500	29	18	110	81	173	0.57
63 x 50	70717600	29	24	110	94	174	0.66

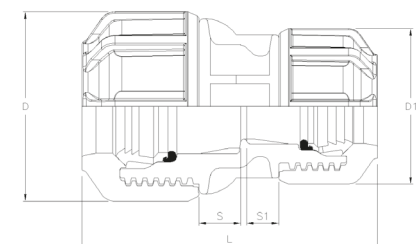

RANGE DIMENSIONS & WEIGHTS

END CONNECTORS (Metric X MI BSP)

Size	Part No.	Dimensions mm.				kg.
		S	D	L	T	Wt
16 x 1/2"	70721100	16	40	66	19.8	0.03
16 x 3/4"	70721200	16	40	68	21.1	0.03
20 x 1/2"	70722100	17	47	73	19.8	0.05
20 x 3/4"	70722200	17	47	75	21.1	0.05
20 x 1"	70722300	17	47	78	24.4	0.05
25 x 1/2"	70723100	19	55	81	19.8	0.07
25 x 3/4"	70723200	19	55	82	21.1	0.07
25 x 1"	70723300	19	55	85	24.4	0.08
32 x 3/4"	70724200	22	67	91	21.1	0.12
32 x 1"	70724300	22	67	94	24.4	0.12
32 x 1-1/4"	70724400	22	67	97	26.7	0.13
32 x 1-1/2"	70724500	22	67	97	26.7	0.13
40 x 1"	70725300	28	81	106	24.4	0.20
40 x 1-1/4"	70725400	28	81	109	26.7	0.20
40 x 1-1/2"	70725500	28	81	109	26.7	0.20
40 x 2"	70725600	28	81	112	31	0.20
50 x 1-1/2"	70726500	30	94	118	26.7	0.30
50 x 2"	70726600	30	94	119	31	0.31
63 x 1-1/2"	70727500	36	110	132	26.7	0.40
63 x 2"	70727600	36	110	127	31	0.41

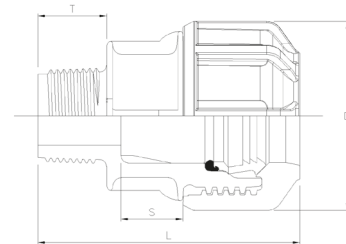

END CONNECTORS (Metric X FI BSP)

Size	Part No.	Dimensions mm.				kg.
		S	D	L	T	Wt
16 x 1/2"	70781100	9	40	62	22.8	0.03
16 x 3/4"	70781200	9	40	63	24.1	0.04
20 x 1/2"	70782100	10	47	71	22.8	0.05
20 x 3/4"	70782200	10	47	70	24.1	0.05
20 x 1"	70782300	10	47	73	27.4	0.05
25 x 1/2"	70783100	11	55	74	22.8	0.08
25 x 3/4"	70783200	11	55	71	24.1	0.08
25 x 1"	70783300	11	55	77	27.4	0.08
32 x 3/4"	70784200	14	67	89	24.1	0.12
32 x 1"	70784300	14	67	88	27.4	0.13
32 x 1-1/4"	70784400	14	67	91	30.2	0.13
40 x 1-1/4"	70785400	18	81	101	30.2	0.20
40 x 1-1/2"	70785500	18	81	101	30.2	0.21
50 x 1-1/2"	70786500	24	94	106	30.2	0.29
50 x 2"	70786600	24	94	107	34.5	0.30
63 x 2"	70787600	29	110	121	34.5	0.44

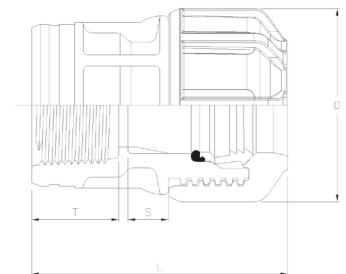

*For advice on chemical resistance properties please contact your nearest Philmac representative.

RANGE DIMENSIONS & WEIGHTS

TEES (Metric X Metric X Metric)

Size	Part No.	Dimensions mm.					kg.
		S	D	H	G	L	Wt
16 x 16 x 16	70731100	9	40	51	30	102	0.08
20 x 20 x 20	70732200	10	47	59	31	117	0.12
25 x 25 x 25	70733300	11	55	67	40	134	0.19
32 x 32 x 32	70734400	14	67	80	48	160	0.33
40 x 40 x 40	70735500	18	81	95	50	182	0.53
50 x 50 x 50	70736600	24	94	101	60	202	0.80
63 x 63 x 63	70737700	29	110	118	73	236	1.22

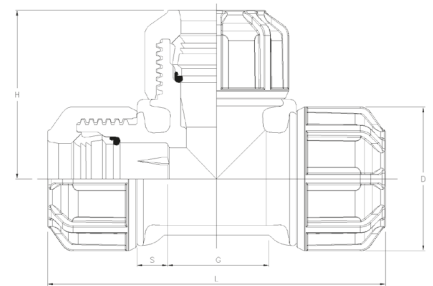

SLIP TEES (Metric X Metric X Metric)

Size	Part No.	Dimensions mm.			kg.
		D	H	L	Wt
20 x 20 x 20	70703220	47	59	117	0.12
25 x 25 x 25	70703330	55	67	134	0.19
32 x 32 x 32	70703440	67	80	160	0.33
40 x 40 x 40	70703550	81	95	182	0.53
50 x 50 x 50	70703660	94	101	202	0.80
63 x 63 x 63	70703770	110	118	236	1.22

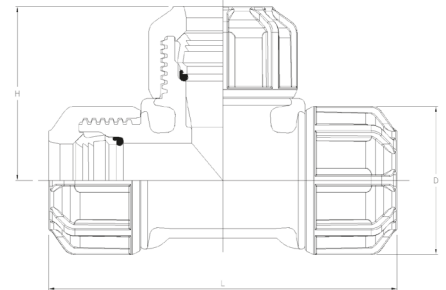

REDUCING TEES (Metric X Metric X Metric)

Size	Part No.	Dimensions mm.							kg.
		S	S1	D	D1	H	G	L	Wt
25 x 25 x 20	70733200	11	10	55	47	64	40	134	0.18
25 x 25 x 32	70733400	11	14	55	64	69	40	134	0.24
32 x 32 x 25	70734300	14	11	67	55	74	40	160	0.30
40 x 40 x 25	70735300	18	11	81	55	74	34	166	0.40
40 x 40 x 32	70735400	18	14	81	67	84	39	171	0.46
50 x 50 x 25	70736300	20	11	94	55	81	35	182	0.63
50 x 50 x 32	70736400	20	14	94	67	90	40	187	0.66
50 x 50 x 40	70736500	24	21	94	81	98	60	197	0.70
63 x 63 x 25	70737300	24	11	110	55	88	29	196	0.82
63 x 63 x 32	70737400	24	14	110	67	98	34	201	0.87
63 x 63 x 50	70737600	29	24	110	94	111	73	220	1.05

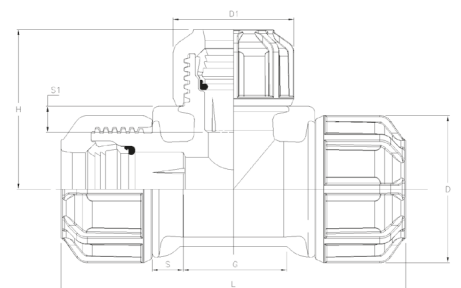

RANGE DIMENSIONS & WEIGHTS

TEES (Metric X Metric X FI BSP)

Size	Part No.	Dimensions mm.						kg.
		S	D	H	G	L	T	Wt
16 x 16 x 1/2"	70741100	9	40	33	30	102	22.8	0.06
20 x 20 x 1/2"	70742100	10	47	38	31	117	22.8	0.09
20 x 20 x 3/4"	70742200	10	47	38	31	117	24.1	0.10
25 x 25 x 1/2"	70743100	11	55	40	40	134	22.8	0.14
25 x 25 x 3/4"	70743200	11	55	41	40	134	24.1	0.15
25 x 25 x 1"	70743300	11	55	44	40	134	27.4	0.16
32 x 32 x 1/2"	70744100	14	67	42	20	135	22.8	0.21
32 x 32 x 3/4"	70744200	14	67	44	48	160	24.1	0.24
32 x 32 x 1"	70744300	14	67	44	48	160	27.4	0.25
32 x 32 x 1-1/4"	70744400	14	67	50	48	160	30.2	0.26
40 x 40 x 1/2"	70745100	18	81	48	19	151	22.8	0.33
40 x 40 x 3/4"	70745200	18	81	50	24	156	24.1	0.34
40 x 40 x 1-1/4"	70745400	18	81	56	50	182	30.2	0.41
40 x 40 x 1-1/2"	70745500	18	81	56	50	182	30.2	0.41
50 x 50 x 1/2"	70746100	24	94	54	19	175	22.8	0.51
50 x 50 x 3/4"	70746200	24	94	57	24	181	24.1	0.53
50 x 50 x 1-1/2"	70746500	24	94	67	60	197	30.2	0.58
50 x 50 x 2"	70746600	24	94	71	60	213	34.5	0.63
63 x 63 x 2"	70747600	29	110	77	73	226	34.5	0.89

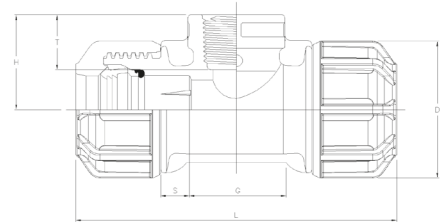

TEES (Metric X Metric X MI BSP)

Size	Part No.	Dimensions mm.						kg.
		S	D	H	G	L	T	Wt
25 x 25 x 1/2"	70793100	11	55	53	35	114	19.8	0.14
25 x 25 x 3/4"	70793200	11	55	54	35	114	21.1	0.15

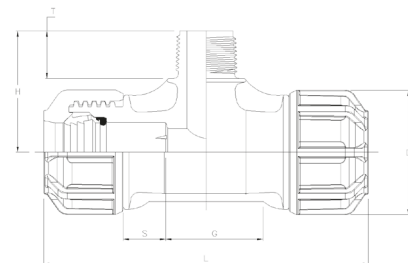

RANGE DIMENSIONS & WEIGHTS

ELBOWS (Metric X Metric)

Size	Part No.	Dimensions mm.			kg.
		S	D	L	Wt
16 x 16	70751100	9	40	51	0.05
20 x 20	70752200	10	47	59	0.07
25 x 20	70753200	11	55	65	0.08
25 x 25	70753300	11	55	67	0.13
32 x 32	70754400	14	67	80	0.22
40 x 40	70755500	18	81	91	0.36
50 x 50	70756600	24	94	101	0.55
63 x 63	70757700	29	110	118	0.85

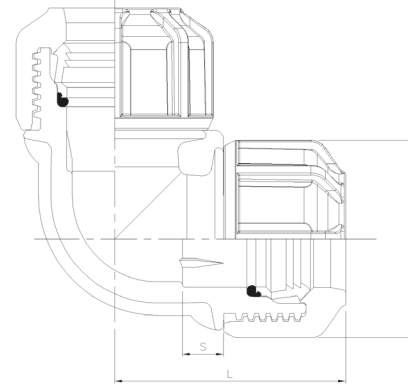

ELBOWS (Metric X FI BSP)

Size	Part No.	Dimensions mm.					kg.
		S	D	H	L	T	Wt
16 x 1/2"	70761100	9	40	67	51	22.8	0.04
20 x 1/2"	70762100	10	47	73	59	22.8	0.05
20 x 3/4"	70762200	10	47	73	59	24.1	0.06
25 x 1/2"	70763100	11	55	88	67	22.8	0.08
25 x 3/4"	70763200	11	55	88	67	24.1	0.08
25 x 1"	70763300	11	55	88	67	27.4	0.09
32 x 1"	70764300	14	67	105	80	27.4	0.14
32 x 1-1/4"	70764400	14	67	105	81	30.2	0.15
40 x 1-1/4"	70765400	18	81	126	91	30.2	0.23
40 x 1-1/2"	70765500	18	81	126	91	30.2	0.24
50 x 1-1/2"	70766500	24	94	142	101	30.2	0.33
50 x 2"	70766600	24	94	142	106	34.5	0.38
63 x 2"	70767600	29	110	160	113	34.5	0.53

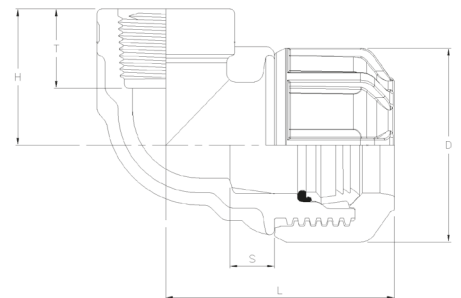

ELBOWS 45° (Metric X Metric)

Size	Part No.	Dimensions mm.			kg.
		S	D	L	Wt
20 x 20	70702800	10	47	47	0.07
25 x 25	70703800	11	55	50	0.13
32 x 32	70704800	14	67	53	0.23
40 x 40	70705800	18	81	67	0.36
50 x 50	70706800	24	94	81	0.56
63 x 63	70707800	29	110	97	0.85

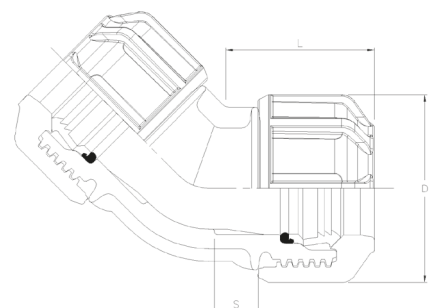

RANGE DIMENSIONS & WEIGHTS

ELBOWS (Metric X MI BSP)

Size	Part No.	Dimensions mm.					kg.
		S	D	H	L	T	Wt
20 x 1/2"	70772100	12	47	43	57	19.8	0.06
25 x 3/4"	70773200	13	55	49	65	21.1	0.07
32 x 1"	70774300	14	67	68	69	24.1	0.07

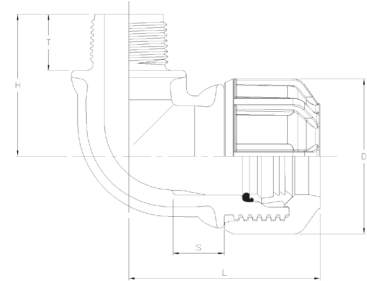

END CAPS (Metric)

Size	Part No.	Dimensions mm.			kg.
		S	D	L	Wt
16	70701900	18	40	50	0.02
20	70702900	19	47	58	0.04
25	70703900	23	55	68	0.07
32	70704900	24	67	78	0.11
40	70705900	31	81	92	0.19
50	70706900	33	94	105	0.29
63	70707900	41	110	124	0.45

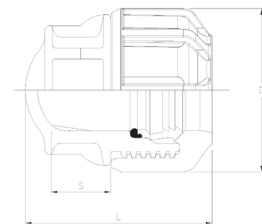

BLANKING SETS

Size (OD)	Ref No
20mm	97 7022 00
25mm	97 7033 00
32mm	97 7044 00
40mm	97 7055 00
50mm	97 7066 00
63mm	97 7077 00

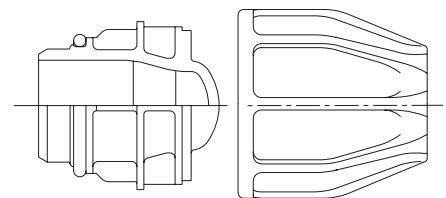

CONNECTS METRIC PE TO A WIDE VARIETY OF PIPES

COUPLER (UTC® X Poly)

Size	Part No.	Dimensions mm.			kg.
		A	B	C	Wt
15-21mm UTC x 20	70103200	114	54	47	0.51
15-21mm UTC x 25	70103300	119	54	55	0.60
21-27mm UTC x 20	70104200	132	66	47	0.73
21-27mm UTC x 25	70104300	130	66	55	0.75
27-34mm UTC x 20	70105200	147	80	47	0.93
27-34mm UTC x 25	70105300	149	80	55	1.16
27-34mm UTC x 32	70105400	150	80	67	1.34
27-34mm UTC x 40	70105500	151	80	81	1.43
39-43mm UTC x 32	70106400	168	96	67	1.91
34-39mm UTC x 32	70107400	153	80	67	1.61
34-39mm UTC x 40	70107500	163	80	81	1.93
47-49mm UTC x 50	70108600	199	96	94	3.23
47-49mm UTC x 63	70108700	201	96	110	3.91
59-61mm UTC x 63	70109700	227	113	110	4.51

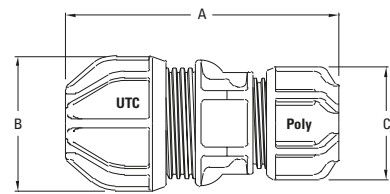

ELBOW 90° (UTC® X Poly)

Size	Part No.	Dimensions mm.				kg.
		A	B	C	D	Wt
15-21mm UTC x 20	70152300	110	54	47	96	0.60
15-21mm UTC x 25	70153300	112	54	55	98	0.66
21-27mm UTC x 25	70154300	119	66	55	106	0.84
21-27mm UTC x 32	70154400	132	66	67	117	1.12
27-34mm UTC x 25	70155300	132	80	55	118	1.16
27-34mm UTC x 32	70155400	142	80	67	126	1.40

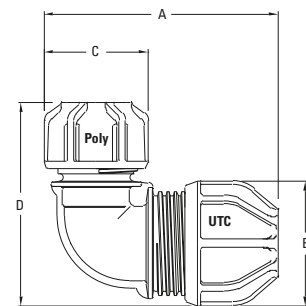

UTC® seals on a wide range of water service pipes and connects to hard and soft materials.

The large rubber seal in UTC® works particularly well on sealing Out-of-Round and Pitted metal pipes.

These include PVC, copper, galvanised, iron, ABS, lead, stainless steel and PE.

Other pipe materials, please consult Philmac or a local representative.

RANGE DIMENSIONS & WEIGHTS

TRANSITION FITTINGS (JOINERS/COUPLING)* (PE Metric x Copper – ASI432)

Size (OD x BSP)	Ref No	Dimensions mm.						kg.
		S	S1	D	G	A/F	L	
16mm x 1/2"	70621100	9	6	40	32	25.4	93	0.13
20mm x 1/2"	70622100	10	6	47	33	25.4	108	0.14
20mm x 3/4"	70622200	10	6	47	33	31.8	108	0.19
25mm x 1/2"	70623100	11	6	56	33	25.4	120	0.18
25mm x 3/4"	70623200	11	6	56	33	31.8	123	0.22
32mm x 3/4"	70624200	14	6	69	33	31.8	140	0.30

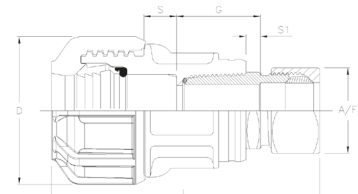

*Supplied with Nut (DR Brass) and Olive.

TRANSITION FITTINGS (ELBOWS)* (PE Metric x Copper – ASI432)

Size (OD)	Ref No	Dimensions mm.						kg.
		S	S1	D	H	A/F	L	
20mm x 1/2"	70672100	10	6	47	62	25.4	59	0.16
25mm x 1/2"	70673100	11	6	56	66	25.4	67	0.19
25mm x 3/4"	70673200	11	6	56	67	31.8	67	0.23

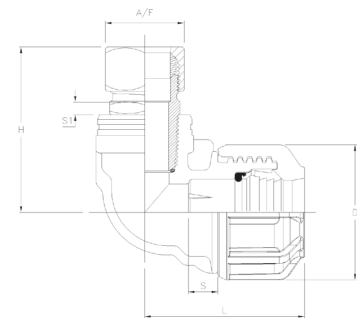

*Supplied with Nut (DR Brass) and Olive.

TRANSITION FITTINGS (TEES)* (PE Metric x Copper – ASI432)

Size (OD x BSP)	Ref No	Dimensions mm.						kg.	
		S	S1	D	H	G	A/F		
20mm x 20mm x 1/2"	70692100	11	6	56	62	40	25.4	117	0.2
25mm x 25mm x 1/2"	70693100	11	6	56	66	40	25.4	134	0.26
25mm x 25mm x 3/4"	70693200	11	6	56	67	40	31.8	134	0.31

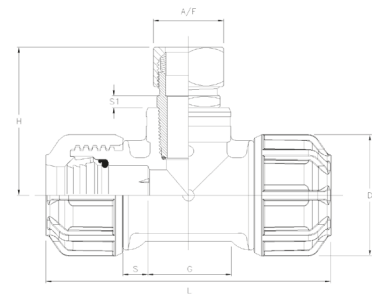

*Supplied with Nut (DR Brass) and Olive.

PRODUCT SPECIFICATION

FITTINGS FOR PE TO PE PIPE CONNECTION

Guidelines for the specifications of Philmac 3G Metric™ compression fittings.

Manufacturer Accreditation

Only fittings manufactured by Manufacturers with a Quality System approved to ISO9001 or equivalent shall be accepted for use.

Product Performance Accreditation

Fittings for Polyethylene (PE) pipes shall meet the applicable performance requirements of ISO 14236 with specific reference to:

- a) Pressure Testing (ISO 3458)
- b) External Pressure resistance testing (ISO 3459)
- c) Resistance to pull out of test assemblies at 20 degrees C (ISO 3501)
- d) Internal pressure resistance when subjected to bending stresses (ISO 3503)

Threaded ends of fittings shall be tapered and conform to ISO7.1 (specification for pipe threads for tubes and fittings where pressure tight joints are made on threads).

Product Material Accreditation

Fittings for Polyethylene (PE) pipes shall have a body made from materials tested in accordance with ISO 9080 (Plastic piping and ducting systems – determination of the long term hydrostatic strength of thermoplastic materials in pipe form by extrapolation).

Performance verification shall be according to test parameters outlined in Clause 8.3.2.2 of ISO 14236 – Verification of long term behaviour.

Fittings shall be suitable for the conveyance of drinking water and shall conform to AS4020 (products for use in contact with water intended for human consumption with regards to their effect on the quality of water).

Product Configuration/ Material Overview

Fittings shall be of the compression fitting type.

Fitting bodies shall be of polypropylene material, the nut shall be of acetal material and the collet shall be of acetal material. Each fitting shall be supplied complete and pre-assembled with captivated collet and seal inside the body.

Seal rings shall be made from nitrile rubber.

Fitting body colour shall be black so as to minimise potential light transmission and/ or UV degradation.

Method of Connection

The seal of a joint will be achieved by nut tightening so as to obtain watertightness by a seal ring around the external diameter of the pipe.

Any pipe preparation will be limited to cutting and cleaning of pipe (for foreign material or burrs). Fittings shall not require the pipe to be lubricated or chamfered during installation.

There shall be no loose components during assembly or disassembly (meaning that the fitting shall not be required to be dismantled during assembly or disassembly and if the nut is removed accidentally components will not fall out of the fitting unless removed deliberately).

Philmac Pty Ltd

53-59 Deeds Road
North Plympton
South Australia
AUSTRALIA 5037

Telephone +61 (8) 8300 9200
Facsimile +61 (8) 8300 9390